

DAVID Y. IGE
GOVERNOR

SHAN S. TSUTSUI
LIEUTENANT GOVERNOR



LINDA CHU TAKAYAMA
DIRECTOR

LEONARD HOSHIO
DEPUTY DIRECTOR

STATE OF HAWAII
DEPARTMENT OF LABOR AND INDUSTRIAL RELATIONS
830 PUNCHBOWL STREET, ROOM 321
HONOLULU, HAWAII 96813
www.labor.hawaii.gov
Phone: (808) 586-8844 / Fax: (808) 586-9099
Email: dir.director@hawaii.gov

February 23, 2017

The Honorable Scott Nishimoto, Chair
Committee on Judiciary
House of Representatives
State Capitol, Room 421
Honolulu, Hawaii 96813

Dear Chair Nishimoto:

Subject: House Bill (HB) 1384, House Draft (HD) 2 Relating to Fire Sprinklers

I am Manuel P. Neves, Chair of the Hawaii State Fire Council (SFC) and Fire Chief of the Honolulu Fire Department (HFD). The SFC and the HFD strongly oppose HB 1384, HD 2, which proposes to permanently prevent the counties in the State of Hawaii (State) from mandating automatic fire sprinklers in new one- and two-family dwellings.

This bill prevents the four counties from incorporating safe building codes particular to their counties. The proper forum for national, model building codes to be reviewed, vetted, and adopted at the State level is the State Building Code Council (SBCC), which is represented by a broad spectrum of stakeholders, including the building industry, architects, structural engineers, building, and fire code officials. The SBCC is continuing its research into the possible use of a 5/8" meter for a residential sprinkler system. This is the standard domestic size meter used on the neighbor islands, which could mean there would be no additional water meter upgrade or cost. We do know that a one-inch meter is not needed to supply a residential sprinkler system. To date, there is no mandate to require residential sprinklers at the State or county level.

We recently received the following cost proposal submitted in February 2016 from a developer on a Department of Hawaiian Home Lands project for 20 turnkey single-family homes in a 45-lot subdivision on Oahu:

| Model | Bedrooms | Baths | Stories | Net Living Area | House Price | Sprinkler System Price | Sprinkler System Price/s.f. | % Sprinkler Price/House |
|-------|----------|-------|---------|-----------------|-------------|------------------------|-----------------------------|-------------------------|
| A | 2 | 1 | 1 | 759 s.f. | \$211,039 | \$7,741 | \$10.20 | 3.6% |
| B | 2 | 2 | 1 | 952 s.f. | \$251,022 | \$9,200 | \$9.70 | 3.6% |
| C | 3 | 2 | 2 | 1,132 s.f. | \$281,385 | \$9,639 | \$8.50 | 3.4% |
| D | 4 | 3 | 2 | 1,496 s.f. | \$320,815 | \$12,120 | \$8.10 | 3.7% |

The sprinkler system cost ranged from approximately \$8-\$10 per square foot and included costs for the design, meter, permit, installation, and profit margin. This revealed a very low percentage compared to the total price of the home. We suggest that the high-cost of housing are related more to supply and demand and the rising prices for land, labor, and building materials.

There is little to no maintenance for a residential sprinkler system. A separate domestic and sprinkler system is maintained by a visual pressure gauge check and an annual flow test, which can be accomplished using a garden hose. A combined system will not need a flow test since the system operates in conjunction with the domestic system.

Eighty-five percent of fire deaths occur in the home, and 84% of the time only one sprinkler head controls the fire. Smoke alarm reliability ranges from 50%-78%, depending on the study. The reliability of a residential fire sprinkler system is 96.6%. Working smoke alarms may alert occupants in time for escape, but do nothing to suppress a fire. The age of a home has little to do with fire occurrences, but are more directly related to human behavior.

The International Residential Code has had a residential sprinkler provision since 2009. California and Maryland require sprinklers in new one- and two-family dwellings statewide along with the District of Columbia. Either through legislation or the code adoption process, 26 states prohibit sprinklers. Eighteen other states do not have a statewide residential sprinkler mandate, but allow local jurisdictions to require them.

Studies have shown that automatic fire sprinklers are effective in reducing fire losses, injuries, and fire-related deaths. There is no equivalent alternative that is as effective in stopping fires as an automatic fire sprinkler system. Although modern homes today have safety building provisions, they are also constructed of light-weight structural components that are susceptible to collapse in a short time during fire exposure. Modern furnishings contribute to rapid fire acceleration and spread, thus reducing escape times greatly.

The Honorable Scott Nishimoto, Chair
Page 3
February 23, 2017

Additional studies performed in California and Maryland demonstrated that the cost of automatic fire sprinklers does not prevent or deter homeowners from purchasing a home. In fact, there was an increase in home sales in some areas.

Life, safety, property conservation, and environmental protection are priorities for the SFC and the HFD. Allowing the passage of this bill to restrict the installation of an automatic fire sprinkler in new one- and two-family homes increases the risk to the public, property, environment, and fire fighters.

The SFC and the HFD strongly urge your committee to defer the passage of HB 1384, HD 1.

Should you have questions, please contact SFC Administrator Socrates Bratakos at 723-7105 or sbratakos@honolulu.gov.

Sincerely,



MANUEL P. NEVES
Chair

MPN/LR:clc

DAVID Y. IGE
GOVERNOR

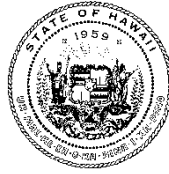

RODERICK BECKER
Comptroller

AUDREY HIDANO
Deputy Comptroller

STATE OF HAWAII
DEPARTMENT OF ACCOUNTING AND GENERAL SERVICES
STATE BUILDING CODE COUNCIL

P.O. BOX 119, HONOLULU, HAWAII 96810-0119

February 23, 2017

The Honorable Scott Y. Nishimoto, Chair
Committee on Judiciary
The House of Representatives
State Capitol, Room 421
Honolulu, Hawaii 96813

Dear Chair Nishimoto:

Subject: House Bill 1384 HD2 Relating to Fire Sprinklers

I am Gaur Johnson, Chair of the State Building Code Council (SBCC). The SBCC provides the following testimony for your information when considering this bill HB 1384 HD2. The original bill proposes to make permanent the prohibition that prevents the counties from requiring fire sprinklers in specific family dwelling units and agricultural and aquacultural buildings. The HD1 version of the bill proposed to extend the prohibition for 10 years. The Committee on Housing amended the bill to its current form HB 1384 HD2. Standing Committee Report Number 668 states that the Committee on Housing removed the date of expiration with the intent to extend the prohibition for less than 10 years.

When the SBCC originally studied this issue a 1-inch water meter was required for residential fire sprinkler systems. More recently it was our understanding that a ¾-inch meter could be used. We have recently received new information that may indicate the standard meter currently used, a 5/8-inch meter, also could work now. We believe that new technology has advanced and will continue to advance in the future and that Act 83 should not be made permanent—these technological advances will reduce cost.

Should you have questions, please contact me at (808) 956-2377 or gaur@hawaii.edu

Sincerely,

GAUR JOHNSON
Chair, State Building Code Council

Harry Kim
Mayor



Wil Okabe
Managing Director

Barbara J. Kossow
Deputy Managing Director

County of Hawai'i

Office of the Mayor

25 Aupuni Street, Suite 2603 • Hilo, Hawai'i 96720 • (808) 961-8211 • Fax (808) 961-6553
KONA: 74-5044 Ane Keohokalole Hwy., Bldg C • Kailua-Kona, Hawai'i 96740
(808) 323-4444 • Fax (808) 323-4440

Dear Chair Nishimoto and members:

Thank you for this opportunity to comment on HB 1384, HD2.

As we all know, the cost of housing in Hawaii is already so high that too many of our citizens are priced out of the market. Whether it is a question of creating housing stock for ownership or rental, we need to find ways to make it less expensive to build, rather than more expensive. For that reason, Hawaii County would not consider requiring sprinklers in residential dwellings, or agricultural or aquacultural buildings.

Respectfully submitted,

Wil Okabe
Managing Director
County of Hawaii

ALAN M ARAKAWA
MAYOR

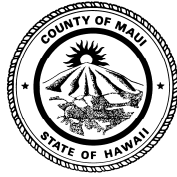

JEFFREY MURRAY
FIRE CHIEF

ROBERT SHIMADA
DEPUTY FIRE CHIEF

COUNTY OF MAUI
DEPARTMENT OF FIRE & PUBLIC SAFETY

200 DAIRY ROAD
KAHULUI, HI 96732
(808) 270-7561
Fax (808) 270-7919

February 23, 2017

The Honorable Scott Nishimoto, Chair
Committee on Judiciary
House of Representatives
State Capitol, Room 421
Honolulu, Hawaii 96813

Dear Chair Nishimoto:

Subject: House Bill (HB) 1384, House Draft (HD) 2 Relating to Fire Sprinklers

I am Jeffrey A. Murray, Member of the Hawaii State Fire Council (SFC) and Fire Chief of the Maui Fire Department (MFD). The SFC and the MFD strongly oppose HB 1384, HD 2, which proposes to permanently prevent the counties in the State of Hawaii (State) from mandating automatic fire sprinklers in new one- and two-family dwellings.

This bill prevents the four counties from incorporating safe building codes particular to their counties. The proper forum for national, model building codes to be reviewed, vetted, and adopted at the State level is the State Building Code Council (SBCC), which is represented by a broad spectrum of stakeholders, including the building industry, architects, structural engineers, building, and fire code officials. The SBCC is continuing its research into the possible use of a 5/8" meter for a residential sprinkler system. This is the standard domestic size meter used on the neighbor islands, which could mean there would be no additional water meter upgrade or cost. We do know that a one-inch meter is not needed to supply a residential sprinkler system. To date, there is no mandate to require residential sprinklers at the State or county level.

We recently received the following cost proposal submitted in February 2016 from a developer on a Department of Hawaiian Home Lands project for 20 turnkey single-family homes in a 45- lot subdivision on Oahu:

| Model | Bedrooms | Baths | Stories | Net Living Area | House Price | Sprinkler System Price | Sprinkler System Price/s.f. | % Sprinkler Price/House |
|-------|----------|-------|---------|-----------------|-------------|------------------------|-----------------------------|-------------------------|
| A | 2 | 1 | 1 | 759 s.f. | \$211,039 | \$7,741 | \$10.20 | 3.6% |
| B | 2 | 2 | 1 | 952 s.f. | \$251,022 | \$9,200 | \$9.70 | 3.6% |
| C | 3 | 2 | 2 | 1,132 s.f. | \$281,385 | \$9,639 | \$8.50 | 3.4% |
| D | 4 | 3 | 2 | 1496 s.f. | \$320,815 | \$12,120 | \$8.10 | 3.7% |

The sprinkler system cost ranged from approximately \$8-\$10 per square foot and included costs for the design, meter, permit, installation, and profit margin. This revealed a very low percentage compared to the total price of the home. We suggest that the high-cost of housing are related more to supply and demand and the rising prices for land, labor, and building materials.

There is little to no maintenance for a residential sprinkler system. A separate domestic and sprinkler system is maintained by a visual pressure gauge check and an annual flow test, which can be accomplished using a garden hose. A combined system will not need a flow test since the system operates in conjunction with the domestic system.

Eighty-five percent of fire deaths occur in the home, and 84% of the time only one sprinkler head controls the fire. Smoke alarm reliability ranges from 50%-78%, depending on the study. The reliability of a residential fire sprinkler system is 96.6%. Working smoke alarms may alert occupants in time for escape, but do nothing to suppress a fire. The age of a home has little to do with fire occurrences, but are more directly related to human behavior.

The International Residential Code has had a residential sprinkler provision since 2009. California and Maryland require sprinklers in new one- and two-family dwellings statewide along with the District of Columbia. Either through legislation or the code adoption process, 26 states prohibit sprinklers. Eighteen other states do not have a statewide residential sprinkler mandate, but allow local jurisdictions to require them.

The Honorable Scott Nishimoto, Chair
Page 3
February 23, 2017

Studies have shown that automatic fire sprinklers are effective in reducing fire losses, injuries, and fire-related deaths. There is no equivalent alternative that is as effective in stopping fires as an automatic fire sprinkler system. Although modern homes today have safety building provisions, they are also constructed of light-weight structural components that are susceptible to collapse in a short time during fire exposure. Modern furnishings contribute to rapid fire acceleration and spread, thus reducing escape times greatly.

Additional studies performed in California and Maryland demonstrated that the cost of automatic fire sprinklers does not prevent or deter homeowners from purchasing a home. In fact, there was an increase in home sales in some areas.

Life, safety, property conservation, and environmental protection are priorities for the SFC and the MFD. Allowing the passage of this bill to restrict the installation of an automatic fire sprinkler in new one- and two-family homes increases the risk to the public, property, environment, and fire fighters.

The SFC and the MFD strongly urge your committee to defer the passage of HB 1384, HD 1.

If you have any questions or concerns, please feel free to call my office at (808) 270-7561.

Sincerely,

A handwritten signature in black ink, appearing to read "Jeffrey A. Murray". The signature is fluid and cursive, with a prominent loop at the end.

JEFFREY A. MURRAY
Fire Chief

**OFFICE OF THE MAYOR
CITY AND COUNTY OF HONOLULU**

530 SOUTH KING STREET, ROOM 300 • HONOLULU, HAWAII 96813
PHONE: (808) 768-4141 • FAX: (808) 768-4242 • INTERNET: www.honolulu.gov

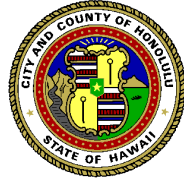

KIRK CALDWELL
MAYOR

ROY K. AMEMIYA, JR.
MANAGING DIRECTOR

GEORGETTE T. DEEMER
DEPUTY MANAGING DIRECTOR

**CITY AND COUNTY OF HONOLULU
BEFORE THE HOUSE COMMITTEE ON JUDICIARY**

FRIDAY, FEBRUARY 24, 2017; 2:00 PM

TO: THE HONORABLE SCOTT NISHIMOTO, CHAIR
THE HONORABLE JOY A. SAN BUENAVENTURA, VICE CHAIR
AND MEMBERS OF THE HOUSE COMMITTEE ON JUDICIARY

FROM: ROY K. AMEMIYA, JR., MANAGING DIRECTOR
CITY AND COUNTY OF HONOLULU

SUBJECT: SUPPORT OF HB1384, HD2

The City and County of Honolulu (City) supports HB1384, HD2, which extends the provisions of Act 83, Session Laws of Hawaii 2012 for an unspecified period. Act 83 temporarily prohibited the counties from requiring fire sprinklers in specific family dwelling units and agricultural and aquacultural buildings, but allows the counties to require fire sprinklers in new homes that require a variance from access road or firefighting water supply requirements.

The City supports making the installation of automatic fire sprinklers optional. The City is concerned about the dramatic increase in housing prices, especially for first-time homebuyers and families. Requiring the installation of automatic fire sprinklers in homes and required upgrades to new water meters would add costs to the already high cost of housing in Hawaii.

Thank you for your consideration of this testimony in support of HB1384, HD2.



 | 808-733-7060

 | 808-737-4977

 | 1259 A'ala Street, Suite 300
Honolulu, HI 96817

February 24, 2017

The Honorable Scott Nishimoto, Chair

House Committee on Judiciary
State Capitol, Room 423
Honolulu, Hawaii 96813

RE: H.B. 1384, H.D.2, Relating to Fire Sprinklers

HEARING: Friday, February 24, 2017, at 2:00 p.m.

Aloha Chair Nishimoto, Vice Chair San Buenaventura, and Members of the Committee,

I am Myoung Oh, Director of Government Affairs, here to testify on behalf of the Hawai'i Association of REALTORS® ("HAR"), the voice of real estate in Hawai'i, and its 9,200 members. HAR **supports** H.B. 1384, H.D.1 which extends the prohibition that prevents the counties from requiring fire sprinklers in specific family dwelling units and agricultural and aquacultural buildings.

HAR believes that building codes serve an important function, as it has broad community impact relating to the health and safety of Hawai'i's residents in their homes. However, when the financial cost of a more stringent building code outweighs the actual safety accomplished, a careful and detailed review should be taken on these building code measures. For example, mandatory fire sprinklers, although well-intentioned, increase the baseline construction cost.

In multi-family dwellings and condominiums, there are usually on-staff professionals who are trained to maintain fire sprinkler systems. However, in a single-family home this is not the case. The average homeowner does not have the skills to be responsible for the ongoing maintenance necessary to keep a fire sprinkler system in operational condition. It would be difficult to create a regulation that increases the base cost of construction and then potentially creating a cottage industry of inspectors/maintenance professionals for maintaining these private sprinkler systems.

Moreover, most fire sprinkler systems call for an additional water meter and separate water line with a back flow prevention device. Because of the high volume of water required in fire sprinkler systems, the standard meter will not suffice. The Board of Water Supply (BWS) charges a high water development fee for water meters, plus the cost of installation, which all adds significant costs to any home. The BWS may determine that the water supply is insufficient for some areas to add fire sprinkler systems and move to deny the permit for those reasons.

REALTOR® is a registered collective membership mark which may be used only by real estate professionals who are members of the NATIONAL ASSOCIATION OF REALTORS® and subscribe to its strict Code of Ethics.





 | 808-733-7060

 | 808-737-4977

 | 1259 A'ala Street, Suite 300
Honolulu, HI 96817

In theory, building codes could adversely affect housing production and could increase housing costs through both substantive (technical) and administrative impediments. However, we would defer specific comments to qualified builders, architects and insurance professionals.

HAR notes that some subdivisions have additional private building standards that are required for housing built within its confines such as minimum square footage, garages vs. carports, etc. These types of design covenants are privately agreed upon and market driven. HAR supports the right of a developer and owners who knowingly purchase within a subdivision with these styles of covenants to continue.

Mahalo for the opportunity to testify in support of this measure.



Testimony of
Christopher Delaunay
Pacific Resource Partnership

House of Representatives
Committee on Judiciary
Rep. Scott Y. Nishimoto, Chair
Rep. Joy A. San Buenaventura, Vice Chair

Notice of Hearing
Friday, February 24, 2017
2:00 P.M.
State Capitol – Room 325

Aloha Chair Nishimoto, Vice Chair San Buenaventura and members of the Committee:

We **support the intent** of HB 1384, HD2 Relating to Fire Sprinklers, which extends the prohibition that prevents the counties from requiring fire sprinklers in specific family dwelling units and non-residential agricultural and aquacultural buildings.

As we all know, we have a housing crisis across the State with the price of homes becoming further out of reach for Hawaii families. Mandating fire sprinklers will increase the cost of a home and outprice many homebuyers with an additional cost of \$35,000 to over \$100,000 depending on area of residence. We believe fire sprinklers should be done voluntarily or as an alternative to installing a fire department access road or water supply.

For the reasons mentioned above, we respectfully request your support on HB 1384, HD2. Thank you for the opportunity to share our views with you.

About PRP

Pacific Resource Partnership (PRP) is a not-for-profit organization that represents the Hawaii Regional Council of Carpenters, the largest construction union in the state, and more than 240 of Hawaii's top contractors. Through this unique partnership, PRP has become an influential voice for responsible construction and an advocate for creating a stronger, more sustainable Hawaii in a way that promotes a vibrant economy, creates jobs and enhances the quality of life for all residents.





HAWAII LABORERS-EMPLOYERS COOPERATION AND EDUCATION TRUST
650 Iwilei Road, Suite 285 · Honolulu, HI 96817 · Phone: 808-845-3238 · Fax: 808-845-8300

**TESTIMONY OF HAWAII LECET
PETER H. M. LEE**

LATE

HOUSE OF REPRESENTATIVES
THE TWENTY-NINTH LEGISLATURE
REGULAR SESSION OF 2017

COMMITTEE ON JUDICIARY
Rep. Scott Y. Nishimoto, Chair
Rep. Joy A. San Buenaventura, Vice Chair

NOTICE OF HEARING

DATE: Friday, February 24, 2017
TIME: 2:00 pm
PLACE: Conference Room 325

TESTIMONY ON HOUSE BILL NO. 1384 HD2, RELATING TO FIRE SPRINKLERS.

ALOHA COMMITTEE CHAIR SCOTT NISHIMOTO, COMMITTEE VICE CHAIR JOY SAN BUENAVENTURA, AND MEMBERS OF THE COMMITTEE ON CONSUMER PROTECTION & COMMERCE:

My name is Peter H. M. Lee, and I am the Construction Compliance Officer of Hawaii LECET. Hawaii LECET is a labor-management partnership between the Hawaii Laborers Union, Local 368, and its unionized contractors.

Mahalo for the opportunity to testify in **SUPPORT** of House Bill No. 1384 HD2. This bill proposes to extend the prohibition that prevents the counties from requiring fire sprinklers in specific family dwelling units and non-residential agricultural and aquacultural buildings.

The price of installing a sprinkler system ranges from \$35,000 to over \$100,000, depending on where you live. It will also depend on the number of sprinkler heads installed, the distance of the house from the water meter, if the pipe needs to be up-sized to attain the minimum flow rate and pressure, and probably the largest cost component, a properly-sized water meter to ensure a fully functioning fire sprinkler system. Mandating fire sprinklers in specific family dwellings will definitely push homeownership further out of reach for local Hawaii families. Let's push for sensible legislation that helps our local families, not hurt them.

For these reasons, we **support House Bill No. 1384 HD2**, and humbly ask its continued passage.

PRESIDENT
EVAN FUJIMOTO
GRAHAM BUILDERS, INC.

PRESIDENT-ELECT
DEAN UCHIDA
SSFM INTERNATIONAL, INC.

VICE PRESIDENT
MARSHALL HICKOX
HOMEWORKS CONSTRUCTION, INC.

SECRETARY
DWIGHT MITSUNAGA
DM PACIFIC, INC.

TREASURER
MICHAEL WATANABE
JW, INC.

SPECIAL APPOINTEE-BUILDER
CURT KIRIU
CK INDEPENDENT LIVING BUILDERS

SPECIAL APPOINTEE-BUILDER
MARK KENNEDY
HASEKO CONSTRUCTION MANAGEMENT
GROUP, INC.

SPECIAL APPOINTEE-ASSOCIATE
PETER ELDRIDGE
RAYNOR OVERHEAD DOORS & GATES

IMMEDIATE PAST PRESIDENT
CRAIG WASHOFSKY
SERVCO HOME & APPLIANCE
DISTRIBUTION

CHIEF EXECUTIVE OFFICER
GLADYS MARRONE
BIA-HAWAII

2017 DIRECTORS

KAREN BERRY
TRADE PUBLISHING COMPANY

CHRIS CHEUNG
CC ENGINEERING & CONSTRUCTION, INC.

CLIFTON CRAWFORD
C & J CONTRACTING, INC.

MARK HERTEL
INTER-ISLAND SOLAR SUPPLY,
OAHU-MAUI-HAWAII-KAUI

BRENTON LIU
DESIGN TRENDS CONSTRUCTION, INC.

SARAH LOVE
BAYS LUNG ROSE & HOLMA

BEAU NOBMANN
HPM BUILDING

GARY OKIMOTO
HONOLULU WOOD TREATING

JACKSON PARKER
D.R. HORTON, SCHULER DIVISION

DOUGLAS PEARSON
CASTLE & COOKE HOMES

PAUL D. SILEN
HAWAIIAN DREDGING
CONSTRUCTION CO. INC.

ALAN TWU
HK CONSTRUCTION CORP.

MAILING:
P.O. BOX 970967
WAIPAHU, HAWAII 96797-0967

PHYSICAL:
94-487 AKOKI STREET
WAIPAHU, HAWAII 96797

Testimony to the House Committee on Judiciary**Friday, February 24, 2017****2:00 p.m.****Conference Room 325****LATE****RE: HB 1384 HD2 – Relating to Fire Sprinklers**

Chair Nishimoto, Vice-Chair San Buenaventura, and members of the committee:

My name is Gladys Quinto-Marrone, CEO of the Building Industry Association of Hawaii (BIA-Hawaii). Chartered in 1955, the Building Industry Association of Hawaii is a professional trade organization affiliated with the National Association of Home Builders, representing the building industry and its associates. BIA-Hawaii takes a leadership role in unifying and promoting the interests of the industry to enhance the quality of life for the people of Hawaii.

BIA-Hawaii supports the intent of H.B. 1384, HD2, which extends the prohibition that prevents the counties from requiring fire sprinklers in specific family dwelling units and agricultural and aquacultural buildings, for an unspecified period.

As several Counties have also either supported removing the sunset date, or stated that they would not mandate residential sprinklers, BIA-Hawaii would prefer the original version of H.B. 1384, that keeps sprinklers optional for the homeowner in perpetuity.

The Committee on Consumer Protection and Commerce (CPC) also requests the Committee on Housing (HSG) to further investigate the impacts that mandated fire sprinkler installation would have on the housing market in Hawaii and whether the ten-year extension is sufficient. CPC also respectfully requests that the HSG consider requiring a legislative report by an agency or department on the impact of mandating the installation of automatic fire sprinklers, including the impact that meter costs, building council mandates, national fire safety standards, and insurance industry incentives and other best practices will have on housing prices.

BIA-Hawaii commissioned a study, by R.M. Towill, to determine the actual cost to design and install an automatic fire sprinkler system, including the charges for a larger water meter, in a single family residence in each County of the State. The report has been attached to our testimony.

BIA-Hawaii is not against fire sprinklers, just the mandating of them. Keeping sprinklers optional is critical in helping to keep housing affordable for Hawaii's families.

Cost prohibitive

The true cost of installing fire sprinklers in single family homes ranges, depending on where in the State you live. The largest cost is from an upgraded water meter, which is required to support a sprinkler system. For a typical 3 bedroom, 2 bath single-family dwelling upgraded to a 1" meter:

Oahu \$10,007.82 (1" meter) + \$25,826.67 (installation costs) = \$35,834.19

Maui \$33,356 (1" meter) + \$32,760.34 (installation costs) = \$66,116.34

Hawaii \$13,750 (1" meter) + \$26,902.80 (installation costs) = \$40,652.80

These are costs provided by actual construction projects. Costs for each system may vary depending on site conditions. On Kauai, the cost of the meter alone is \$35,290. If a larger home is built, a larger meter is required at a much higher cost. For example, to upgrade to a 1 1/2" meter, it would cost \$71,948 on Maui and \$70,580 on Maui, just for the meter. Yearly sprinkler inspections add to the cost of maintenance.

With the median price of a new home on Oahu at approximately \$730,000.00, adding the cost of a fire sprinkler system and larger water meter will dramatically increase the price of a home. The National Association of Home Builders' 2016 data for Hawaii found that for every

Statewide concern

Sprinklers are of statewide concern because housing affordability is a statewide concern, as evidenced by the number of bills this session addressing affordable housing and homelessness. DEBEDT reported that Hawaii needs over 66,000 new housing units through 2015 and significantly adding costs to construction will be more of a barrier to new housing. Furthermore, the State Building Code Council works on codes with county officials that impact all the Counties, so it is not a home rule issue.

Prevention and education are critical

Proponents say the contents of your home, which they say are made of materials that burn faster, cause fires. Educating the public on this is critical in prevention. Nationally, the number one cause of home fires is cooking. The public should instead be informed that cost-effective fire suppression canisters placed above your stove help prevent such fires from spreading, and also prevent any water damage that will result from a fire sprinkler.

Working smoke detectors save lives

National organizations such as the American Red Cross advocate for a working smoke detector and an escape plan to help keep your family safe during a fire. According to the National Fire Protection Association (NFPA), the fire survival rate in homes with working smoke detectors is 99.41% and only rises to 99.6% with a sprinkler. However, the cost difference between the two systems is quite significant.

New homes are safer and older homes burn

New homes are constructed with technology that offers safer, more durable building materials and products than ever before. Interconnected smoke alarms, and other improvements mean you and your family are safer than ever.

The age of the home is an important piece of information when discussing residential fires, because various aspects of older homes can make them more prone to fires and more dangerous in the case one occurs. The leading causes of unintentional home structure fires are 1) cooking equipment, 2) heating equipment and 3) electrical distribution and lighting equipment. A strong relationship between housing age and the rate of electrical fires has been observed, with housing over 40 years old having the strongest association with electrical distribution fires.

Based on data from the Honolulu Fire Department, 77% of fires occurring in residential structures between 2009 and 2015 involved homes built before 1980. Building codes have dramatically increased since 1980. The improvements to fire safety required by building codes do not evaporate with age, so it can be expected that homes built today will continue to outperform those built several generations ago.

BIA-Hawaii members would benefit

Many of BIA's members would benefit from a mandate, but they support keeping sprinklers optional because if no homes are built due to the increased cost, then there will be nowhere to install plumbing or supply piping. Furthermore, pipes filled with water within your walls and ceilings run the risk of leakage, leading to water damage and mold.

Not a national trend

Twenty-four States defeated a sprinkler mandate through their code adoption process and 20 States defeated the mandate legislatively. Only California, Maryland, and the District of Columbia have adopted a mandate.

We do not want to place homeowners or firefighters in unnecessary danger resulting from a one or two family structure fire. We believe that there are more cost-effective means available that would provide the same level of protection at a fraction of the cost of a new fire sprinkler system and larger water meter.

Our main concern is the impact a sprinkler mandate would have on the affordability of housing in Hawaii.

We **support** H.B. 1384, to keep residential sprinklers optional. Thank you for the opportunity to express our views on this matter.

Hawai'i State Fire Council
c/o Honolulu Fire Department
636 South Street
Honolulu, HI 96813

LATE

February 24, 2017

The Honorable Scott Nishimoto, Chair
Committee on Judiciary
The State House of Representatives
State Capitol, Room 421
Honolulu, Hawaii 96813

Dear Chair Nishimoto:

Subject: House Bill (HB) 1384, House Draft (HD) 2 Relating to Fire Sprinklers

I am Robert F. Westerman, Vice-Chair of the Hawaii State Fire Council (SFC). The SFC strongly oppose HB 1384, HD 2, which proposes to permanently prevent the counties in the State of Hawaii (State) from mandating automatic fire sprinklers in new one- and two-family dwellings.

This bill prevents the four counties from incorporating safe building codes particular to their counties. The proper forum for national, model building codes to be reviewed, vetted, and adopted at the State level is the State Building Code Council (SBCC), which is represented by a broad spectrum of stakeholders, including the building industry, architects, structural engineers, building, and fire code officials. The SBCC is continuing its research into the possible use of a 5/8" meter for a residential sprinkler system. This is the standard domestic size meter used on the neighbor islands, which could mean there would be no additional water meter upgrade or cost. We do know that a one-inch meter is not needed to supply a residential sprinkler system. To date, there is no mandate to require residential sprinklers at the State or county level.

We recently received the following cost proposal submitted in February 2016 from a developer on a Department of Hawaiian Home Lands project for 20 turnkey single-family homes in a 45-lot subdivision on Oahu:

| Model | Bedrooms | Baths | Stories | Net Living Area | House Price | Sprinkler System Price | Sprinkler System Price/s.f. | % Sprinkler Price/House |
|-------|----------|-------|---------|-----------------|-------------|------------------------|-----------------------------|-------------------------|
| A | 2 | 1 | 1 | 759 s.f. | \$211,039 | \$7,741 | \$10.20 | 3.6% |
| B | 2 | 2 | 1 | 952 s.f. | \$251,022 | \$9,200 | \$9.70 | 3.6% |
| C | 3 | 2 | 2 | 1,132 s.f. | \$281,385 | \$9,639 | \$8.50 | 3.4% |
| D | 4 | 3 | 2 | 1496 s.f. | \$320,815 | \$12,120 | \$8.10 | 3.7% |

The sprinkler system cost ranged from approximately \$8-\$10 per square foot and included costs for the design, meter, permit, installation, and profit margin. This revealed a very low percentage compared to the total price of the home. We suggest that the high-cost of housing are related more to supply and demand and the rising prices for land, labor, and building materials.

There is little to no maintenance for a residential sprinkler system. A separate domestic and sprinkler system is maintained by a visual pressure gauge check and an annual flow test, which can be accomplished using a garden hose. A combined system will not need a flow test since the system operates in conjunction with the domestic system.

Eighty-five percent of fire deaths occur in the home, and 84% of the time only one sprinkler head controls the fire. Smoke alarm reliability ranges from 50%-78%, depending on the study. The reliability of a residential fire sprinkler system is 96.6%. Working smoke alarms may alert occupants in time for escape, but do nothing to suppress a fire. The age of a home has little to do with fire occurrences, but are more directly related to human behavior.

The International Residential Code has had a residential sprinkler provision since 2009. California and Maryland require sprinklers in new one- and two-family dwellings statewide along with the District of Columbia. Either through legislation or the code

The Honorable Scott Nishimoto, Chair

Page 3

February 24, 2017

adoption process, 26 states prohibit sprinklers. Eighteen other states do not have a statewide residential sprinkler mandate, but allow local jurisdictions to require them.

Studies have shown that automatic fire sprinklers are effective in reducing fire losses, injuries, and fire-related deaths. There is no equivalent alternative that is as effective in stopping fires as an automatic fire sprinkler system. Although modern homes today have safety building provisions, they are also constructed of light-weight structural components that are susceptible to collapse in a short time during fire exposure. Modern furnishings contribute to rapid fire acceleration and spread, thus reducing escape times greatly.

Additional studies performed in California and Maryland demonstrated that the cost of automatic fire sprinklers does not prevent or deter homeowners from purchasing a home. In fact, there was an increase in home sales in some areas.

Life, safety, property conservation, and environmental protection are priorities for the SFC and the HFD. Allowing the passage of this bill to restrict the installation of an automatic fire sprinkler in new one- and two-family homes increases the risk to the public, property, environment, and fire fighters.

The SFC strongly urge your committee to defer the passage of HB 1384, HD 2.

Please contact me at (808) 241-4975 or rwesterman@kauai.gov should you have any questions or require additional information regarding this matter.

Sincerely,



Robert Westerman
Vice Chair, Hawai'i State Fire Council

RFW/dag

LATE

JUDtestimony

From: Stefanie Sakamoto Lee <stef@sakamotoconsulting.com>
Sent: Thursday, February 23, 2017 6:09 PM
To: JUDtestimony
Subject: Testimony for HB1384
Attachments: 161128 FINAL BIA Fire Sprinkler Report (1).pdf

Aloha,

I submitted the testimony for BIA Hawaii through the system, however, the report that is referenced in our testimony is too large to be uploaded through the system. It is attached here.

Please let me know if there are any questions or concerns. Mahalo!

Stefanie Y. Sakamoto Lee
Sakamoto Consulting, LLC
(808) 387-5501
stef@sakamotoconsulting.com

Analysis on the Impact of Mandating Automatic Fire Sprinkler Systems in Hawaii

International Residential Code 2012 Mandates the Installation of Automatic Fire Sprinkler in All One and Two Family Dwellings

Building Industry of Association of Hawaii (BIA-Hawaii)
National Association of Home Builders (NAHB)

November 2016



Submitted By

SSFM INTERNATIONAL, INC.

Project Managers, Planners, & Engineers

501 Sumner Street, Suite 620

Honolulu, Hawaii 96817

Phone: (808) 531-1308

Fax: (808) 521-7348

Email: duchida@ssfm.com

SSFM
INTERNATIONAL

Table of Contents

| | |
|---|-----------|
| Executive Summary | 3 |
| I. Scope of Work | 5 |
| II. Background | 6 |
| III. Objective | 7 |
| IV. Approach | 8 |
| V. Analysis | 9 |
| Position 1—New Lightweight Structural Material Burn Faster than Lumber | 9 |
| Position 2--Fires More Likely in Older Homes | 11 |
| Position3—Survival Rates—Smoke Detectors vs Fire Sprinklers | 12 |
| Position 4—Cost of Fire Sprinklers in Hawaii | 13 |
| Position 5—Fire Sprinklers Will Make Homes Less Affordable | 16 |
| Position 6—Upgrading Water Meter | 18 |
| VI. Cost Estimates for New Homes in Hawaii with Fire Sprinklers | 22 |
| VII. Conclusions and Recommendations | 23 |

Executive Summary (Repeal of Sunset date in Act 83, 2012 SLH)

Background:

The National Fire Protection Association (NFPA) has been successful in having the installation of automatic fire sprinkler systems required in all new one and two family dwellings included in the International Residential Code (IRC) for 2012.

In 2012, the Legislature passed Act 83, 2012 SLH that prohibited any County from requiring the installation of automatic fire sprinklers in any new or existing one or two family dwelling.

This prohibition on the mandate expires on June 30, 2017.

BIA Hawaii will be submitting legislation in the 2017 legislative session that will seek to remove the sunset from Act 83, and thus allowing for the prohibition on the mandate to become permanent.

Analysis:

Unprotected lightweight construction failed in 6 minutes when compared to dimensional sawn cut lumber, which failed in approximately 19 minutes. This is a primary reason national model building codes require residential sprinklers in new one- and two-family homes and rated protection of lightweight structural components. It protects, not only the occupants, but fire fighters.

The discussion on lightweight components is typically focused on unfinished basements, because the floor joists may be exposed while the home is occupied. However, homes in Hawaii do not have basements, so the argument about structural components is moot.

Nevertheless, according to UL's 2012 report Analysis of Changing Residential Fire Dynamics and Its Implications on Firefighter Operational Timeframes, research demonstrated that a single layer of 1/2-inch gypsum wall board on the bottom of the unprotected floor assembly adds on average approximately 20 minutes to the time before collapse. This is a standard method of passive fire protection and applies to both legacy and modern construction. According to the UL study, firefighters can still expect close to 30 minutes of structural integrity in newer homes with a wood I joist floor with a layer of gypsum wallboard on the underside of the joists.

Our research shows that mandating the installation of automatic fire sprinklers in one and two family dwellings in Hawaii, will increase the price of a home in Hawaii by roughly \$25,000.00 to \$32,000.00.

The cost to install a new, larger water meter that will be required when an automatic fire sprinkler system is installed will add roughly \$6,500.00 to \$26,500.00 to the overall cost of a new home in Hawaii.

Conclusion:

The difference in cost between a new automatic fire sprinkler system with associated increases in water meter size versus the cost of additional gypsum board to cover any exposed lightweight structural materials in new home construction is several thousand dollars.

We firmly believe that there are other, more cost effective methods that will not only protect fire fighters and homeowners but will not significantly increase the price of a new home in Hawaii.

As such, we believe that Section 3 (the Sunset provision) of Act 83, SLH 2012 be deleted or removed. This would prohibit the Counties from requiring the installation or retrofiting of automatic fire sprinklers or an automatic tire sprinkler system in any new construction of one or two family residential dwellings.

I. Scope of Work

BIA Hawaii has contracted with SSFM International, Inc., to prepare a report analyzing the efforts by the National Fire Protection Association (NFPA) and the local Fire Departments to adopt the International Residential Building Code (IRC) provisions that would mandate the installation of an automatic fire sprinkler system in all new one and two family dwellings.

The report will provide research on the rationale for the mandate; impacts to the cost of housing on all counties in Hawaii; and cost effective alternatives to mandating fire sprinklers.

Know Your Fire Sprinkler Systems Components

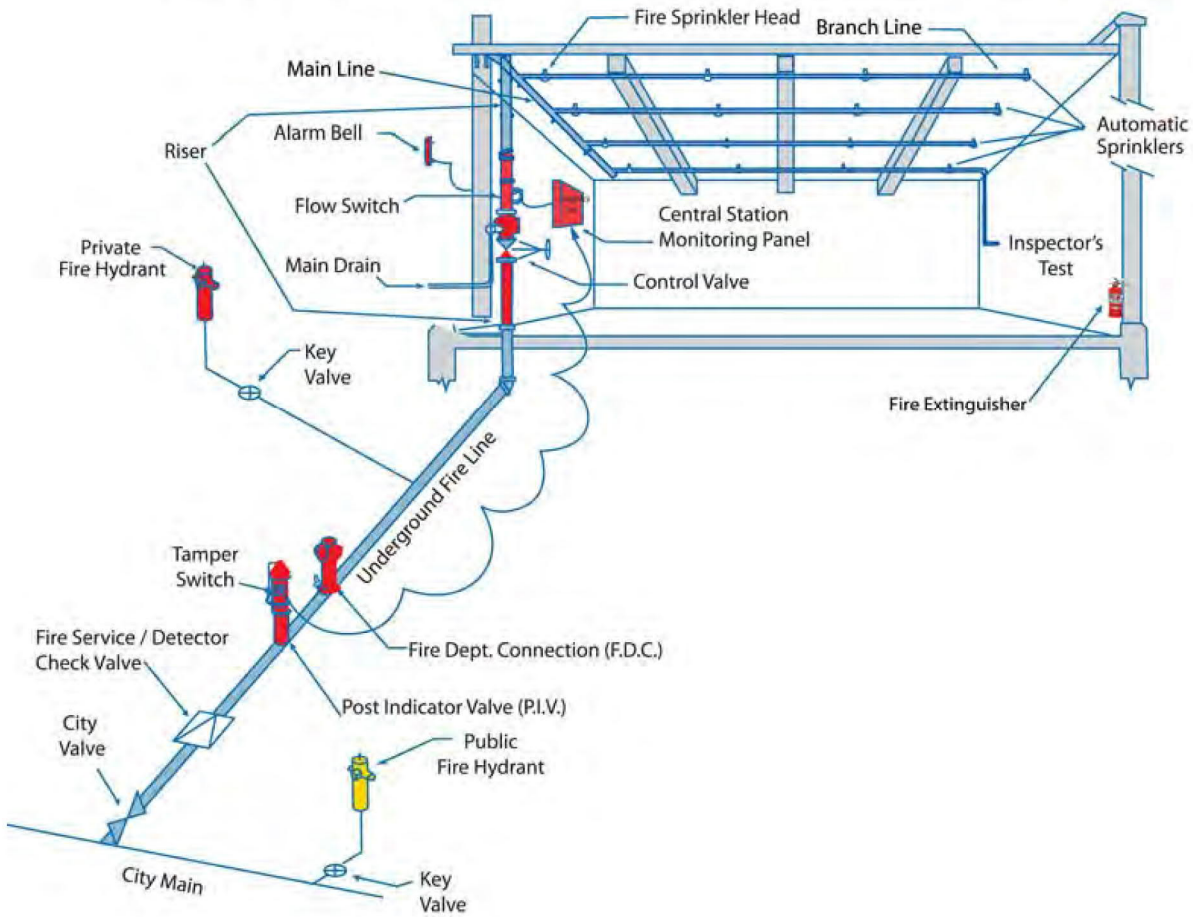

II. Background

Organizations such as the National Fire Protection Association (NFPA) have been successful in having the installation of automatic fire sprinkler systems required in all new one and two family dwellings included in the International Residential Code (IRC) for 2012 (SEE EXHIBIT "A").

In 2012, the BIA was successful in having legislation passed (SEE EXHIBIT "B"--Act 83, 2012 SLH) that prohibited any County from requiring the installation of automatic fire sprinklers in any new or existing one or two family dwelling. The specific language amended Chapter 46 Hawaii Revised Statutes with the following:

No county shall require the installation or retrofitting of automatic fire sprinklers or a new automatic fire sprinkler system in:

- 1) Any new or existing detached one or two family dwelling unit in a structure used only for residential purposes; and,
- 2) Non-residential agriculture and aquaculture buildings and structures located outside an urban area;

Provided that this section shall not apply to new homes that require a variance from access road or fire-fighting water supply requirements.

This prohibition on the mandate expires on June 30, 2017.

With the prohibition expiring in June of 2017, the Hawaii State Building Code Council is considering adopting the 2012 IRC which would MANDATE the installation of an automatic fire sprinkler system in all new one and two family dwellings. Each County would have the opportunity to adopt the 2012 IRC "as is" similar to the State Building Code Council, or the County could have the mandate removed as a part of its adoption at the county level.

If the residential building code is silent on not requiring the installation of automatic fire sprinklers on new one and two family dwellings, the Fire Department in each county could require fire sprinklers be installed in all new one and two family dwellings as a part of the "Fire Code."

Currently, only Maryland, California, and the District of Columbia have adopted codes that require fire sprinklers on all new one and two family dwellings. None of the other 48 States and/or their respective counties have mandated the installation of automatic fire sprinklers on new one and two family dwellings.

III. Objective

BIA Hawaii will be leading an effort to have legislation introduced that would “Prohibit” any county from mandating the installation of automatic fire sprinkler systems in all one and two family dwellings. By law, we would remove the ability of the State Building Code Council and the individual Counties for adopting the 2012 IRC which would require the mandate. Installation of automatic fire sprinkler systems will remain as an “option” to new home buyers.



IV. Approach

The question before the elected officials is:

Should the State of Hawaii (State Building Code Council and All Counties) adopt a residential construction code that would require automatic fire sprinkler systems be installed in all new one and two family dwellings?

- Yes, because it will save lives and protect property.
 - New building materials (i.e. lightweight structural components) and content—dwelling burn faster, and the overarching goal is to protect not only occupants but fire fighters

- No, because:
 - New home construction will incorporate materials and methods that will increase the performance of new building materials (i.e. lightweight structural components) in a residential structural fire; AND,
 - It will increase the overall price of a new residential dwelling.
 - Cost for a fire sprinkler system on each county
 - Cost for larger water meter (higher pressure)
 - Higher cost for dwellings located in Rural/Urban Fringe areas (lack of water pressure or lack of County System)—Catchment or private system/well

This report will provide the specific position expressed by the National Fire Protection Association (NFPA) and the respective County Fire Departments on the need to “MANDATE” the installation of an automatic fire sprinkler systems in all new one and two family dwellings.

The report will also provide a counter position expressed by the National Association of Home Builders (NAHB) and BIA Hawaii on keeping the installation of an automatic fire sprinkler systems as an “OPTION.”

V. Analysis

Position 1: Automatic Fire Sprinkler Systems must be required on all new one and two family dwellings because new building materials (i.e. lightweight structural components) and content burn faster than traditional sawn cut lumber, and the overarching goal is to protect not only occupants but fire fighters.

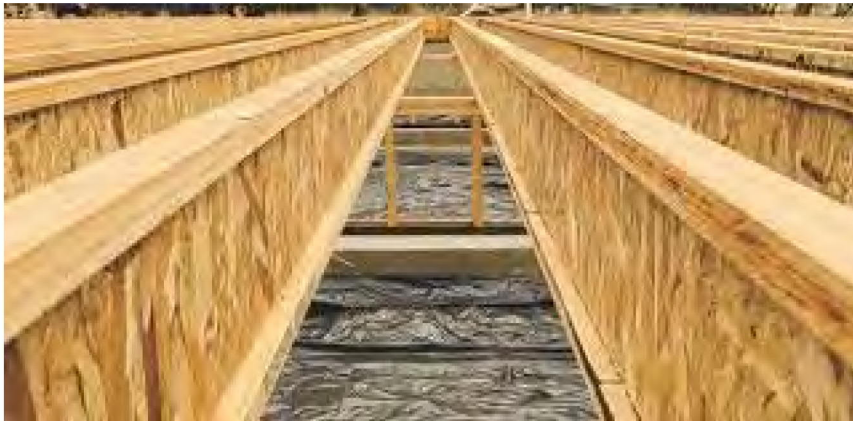

STATE FIRE COUNCIL RESPONSE:

A report in 2008 by Underwriters Laboratories (UL), “Structural Stability of Engineered Lumber in Fire Conditions,” studied the building materials used in today’s modern homes. Structural components were exposed to the point of collapse where it was demonstrated that unprotected lightweight construction failed in 6 minutes when compared to dimensional sawn cut lumber, which failed in approximately 19 minutes. ***This is a primary reason national model building codes require residential sprinklers in new one- and two-family homes and rated protection of lightweight structural components. It protects, not only the occupants, but fire fighters.***

A study by UL (<http://newscience.ul.com/articles/modern-residential-fires>) found “the modern home fire is a ‘perfect storm’ of conditions and outcomes: larger homes + open house geometries + increased fuel loads + new construction materials = faster fire propagation, shorter time to flashover, rapid changes in fire dynamics, shorter escape times, and shorter structural collapse times.”

NAHB RESPONSE:

When listing factors that impact residential fires, the UL studies ignored the hundreds of code changes that have improved passive fire resistance, heating and electrical equipment since the 1970s. A better way to determine whether newer homes are safer is by evaluating national fire data in the real world. In states where NAHB has looked at such data and matched it with the age of affected homes, fatalities are heavily concentrated in older homes.

The discussion on lightweight components is typically focused on unfinished basements, because the floor joists may be exposed while the home is occupied. However, homes in Hawaii do not have basements, so the argument about structural components is moot.

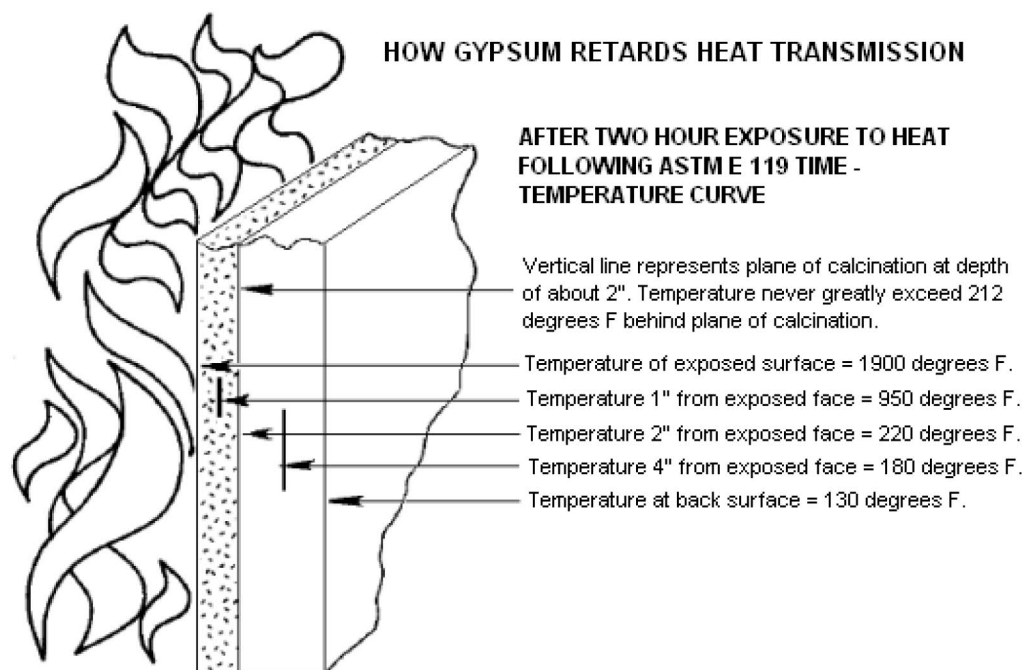

(Data from Underwriters Laboratories, Inc.)

According to UL's 2012 report Analysis of Changing Residential Fire Dynamics and Its Implications on Firefighter Operational Timeframes, research demonstrated that a single layer of 1/2-inch gypsum wall board on the bottom of the unprotected floor assembly adds on average approximately 20 minutes to the time before collapse. This is a standard method of passive fire protection and applies to both legacy and modern construction. According to the UL study, firefighters can still expect close to 30 minutes of structural integrity in newer homes with a wood I joist floor with a layer of gypsum wallboard on the underside of the joists.

The UL studies mentioned in the SFC letter either looked at the conditions mentioned individually, or used experimental rooms based on guesses about important differences between older and newer homes. Many of the differences were in room furnishings rather than in construction of the rooms themselves, so the results are not particularly informative about issues of construction.

Position 2: Fires are more likely in older home than in newer homes.

STATE FIRE COUNCIL RESPONSE:

In the NFPA’s “The Case for Fire Sprinklers in One- and Two-Family Dwellings, Revised October 2014,” the age of housing is a poor predictor of fire death rates. When older housing is associated with higher rates, it is because older housing tends to have a disproportionate share of poorer, less educated households. Statistically, the only fire safety issue that is relevant to the age of the home is outdated electrical wiring. Beyond that, the age of the home has little or nothing to do with fire safety.

BIA HAWAII RESPONSE:

The following table was compiled from information provided by the Honolulu Fire Department on residential structure fires from 2009 thru 2015. On Oahu, over the last 6.5 years (2009 thru May 2015) there were a total of 583 residential structural fires. Of the 583 fires, 23% or 136 structures were constructed between 1981 and 2010. 77% or 447 structures were built between 1900 and 1980. The downward trend in residential structural fires on dwellings constructed over the last 30+ years can be attributed to a number of different variables such as: better or improved response time in first responders; improved residential construction codes requiring fire rated materials: increased public awareness on fire prevention.

| OAHU RESIDENTIAL FIRES--AGE OF STRUCTURES | | | | | | | | | |
|--|--------------|-----------|-----------|-----------|------------|------------|-----------|--------------|-------------|
| Age of Structure Fires: 2009 | Year of Fire | | | | | | | Total By Age | % of Total |
| | 2009 | 2010 | 2011 | 2012 | 2013 | 2014 | 2015 | | |
| 1900-1950 | 8 | 13 | 13 | 15 | 29 | 15 | 10 | 103 | 18% |
| 1951-1960 | 15 | 17 | 24 | 22 | 9 | 23 | 11 | 121 | 21% |
| 1961-1970 | 19 | 19 | 14 | 22 | 25 | 28 | 4 | 131 | 22% |
| 1971-1980 | 15 | 13 | 17 | 16 | 15 | 9 | 7 | 92 | 16% |
| 1981-1990 | 7 | 19 | 11 | 4 | 10 | 11 | 2 | 64 | 11% |
| 1991-2000 | 7 | 5 | 10 | 4 | 10 | 9 | 4 | 49 | 8% |
| 2001-2010 | 2 | 2 | 4 | 3 | 3 | 7 | 2 | 23 | 4% |
| Total | 73 | 88 | 93 | 86 | 101 | 102 | 40 | 583 | 100% |

Position 3: According to the National Fire Protection Association (NFPA), the fire survival rate in homes with working smoke detectors is 99.41% and only rises to 99.6% with a sprinkler.

STATE FIRE COUNCIL RESPONSE:

According to Fire Sprinkler Initiative's (FSI), Myths vs Facts, a 100% chance of dying would mean that every fire is fatal or roughly 100 deaths per 100 fires. Fortunately, that is not the case. The chances of surviving a home fire when smoke alarms are present is 99.45% (100 minus .55) vs. 98.87 (100 minus 1.13) in home fires with no working smoke alarms. The first number is barely higher than the second. The above-mentioned statistics are based on "chances of survival," which is not the same as "risk of fire death," based on the total number of fires.

NAHB RESPONSE:

The above argument simply highlights a different view of the issue. It is, in fact, correct to say that the survivability, when a large or small fire occurs is 99.45% with at least one operating smoke alarm. The difference highlighted by the SFC response is that its data is based on the number of reported fires. Furthermore, this data includes fires that occurred in apartment buildings, so that it should not be considered for new, one- and two-family homes.

The effectiveness of smoke alarms cannot be underestimated. According to NFPA, since the time that smoke alarms have been required in dwellings, there has been a significant drop in the number of reported fires, injuries and fatalities in the United States. Since 1980, the number of fires has dropped by 50 percent and fatalities have dropped by about the same margin, all during the same time period where the population increased and where smoke alarms were required in the model codes but sprinklers were not. And smoke alarms continue to become more effective with ongoing technical advances.



Such improvements include the proliferation of 10-year integral batteries, which substantially lengthen the interval between low-battery signals. Batteries in these units also cannot be used in other devices, which eliminates the possibility of the battery being removed to power other

electronic devices. There is also continued research aimed at improving the detection logarithm to greatly reduce false alarms from cooking. All these improvements are still unfolding, and can be expected to further reduce the number of fatalities.

According to NFPA, three out of five home fire deaths resulted from fires in properties without at least one working, battery-operated smoke alarm. Hardwired, interconnected smoke alarms are installed in new homes, which are more likely to operate and alert occupants to a fire. As for the remaining existing homes, ensuring every home in the U.S. had at least one working smoke alarm would save close to 900 lives each year.

Position 4: Mandatory fire sprinklers could add between \$18,000 to over \$23,000 to a new home in Honolulu and even more on the neighbor islands



STATE FIRE COUNCIL RESPONSE:

According to the City and County of Honolulu's (City) Department of Planning and Permitting's permit records from 2010 to 2014, the average home size in Honolulu was 2,785 square feet. The sprinkler installation cost would be \$13,089, based on an average of four contractors' installation cost of \$4.70 per square feet taken from the State Building Code Council's "Investigative Committee's Report on Fire Sprinkler Implementation in New One- and Two-Family Dwellings dated June 25, 2013." As of September 2015, the median home price in Hawaii was approximately \$730,000, amounting to less than 2% of the total home price.

The standard meter for domestic water use for a one- or two-family dwelling in the City is three-quarters of an inch and adequate to supply a residential fire sprinkler system at no additional cost.

There is a higher cost on the neighbor islands, which is primarily due to the need to increase diameter size in the residential water meter from five-eighths to three-quarters of an inch. Kauai, Hawaii, and Maui counties estimate an increase of \$7,000, \$9,000, and \$12,854, respectively, for the larger meter and \$20,089, \$22,089, and \$25,943, respectively, for sprinkler and meter installation costs. This equates to an increase of a 2.8%, 3.0%, and 3.6%, respectively, for the median-priced home. These added costs are relatively small over the duration of a standard 30-year mortgage, compared with the life safety benefit of protecting families from fires in their homes.



The Federal Department of Housing and Urban Development (HUD) published the 2016 HUD Affordable Sales Price Guideline for Honolulu (See Exhibit "C"). It shows the Average Median Income (AMI) and price guideline at different interest rates. Currently, a family of four (4) would have to have an income at the 140% of the Average Median Income (AMI) and obtain a 30 year fixed mortgage at 3.5% or less in order to afford the median price Single Family home on Oahu (\$747,500.00). When the additional cost of the automatic sprinkler system is included, interest rates at that upper end of the income (i.e. 140%) would have to be at 3.0% in order for a family of four (4) to afford to purchase the house with the added cost of the fire sprinkler system.

BIA HAWAII RESPONSE:

The following are actual construction cost for the installation of an automatic fire sprinkler system on Oahu, Maui and Hawaii. No data has been obtain for Kauai.

| Cost Breakdown | Oahu | Maui | Hawaii |
|--|--|--|-----------------------|
| Cost Analysis Fire Sprinkler Install | Two Story Home (Flag Lot) (Homeworks) | Cost Per Units--3 Plex, 2 Story (Stanford Carr) | Two Story Home |
| Size of Unit (SQFT) | 3,794.00 | 1,905.00 | 2,000.00 |
| DESCRIPTION | | | |
| Plans and Install of System | \$16,750.00 | \$26,388.33 | \$15,000.00 |
| Site Work (Trenching for new water line) | | | |
| Added Permit cost | \$68.94 | \$263.88 | \$135.00 |
| Fire Chief review(?) 10% of permit fee | \$539.00 | \$290.27 | \$1,500.00 |
| Plumber additional cost to upgrade to 1" line | \$1,400.00 | | \$2,745.00 |
| Plumber additional cost Regulator/backflow misc. | \$650.00 | | \$1,275.00 |
| Painter -additional masking L&M | \$425.00 | 250 | \$588.00 |
| Drywall-additional cost of install | \$400.00 | | \$588.00 |
| Electrician (wiring of bell/monitor stations) | \$300.00 | 1250 | \$588.00 |
| <i>Sum of hard costs</i> | <i>\$20,532.94</i> | <i>\$28,442.49</i> | <i>\$22,419.00</i> |
| G.C Overhead 15% | \$ 3,079.94 | \$ 1,422.12 | \$ 3,362.85 |
| G.C.Profit 5% | \$1,180.64 | \$1,422.12 | \$1,120.95 |
| GET | \$ 1,033.15 | \$ 1,473.61 | |
| Final Cost/Unit | \$25,826.67 | \$32,760.34 | \$26,902.80 |
| Cost per sq.ft. | \$ 6.81 | \$ 17.20 | \$ 13.45 |

Our research shows that mandating the installation of automatic fire sprinklers in one and two family dwellings in Hawaii, will increase the price of a home in Hawaii by roughly \$25,000.00 to \$32,000.00.

The costs are only of the installation of an automatic fire sprinkler system and do not include the additional cost to install a new larger meter (see below).

Position 5: Fire Sprinklers: Impacting the Supply of New Housing and Making Homes Less Affordable for Everyone

STATE FIRE COUNCIL RESPONSE:

An NFPA study in June 2009, “Comparative Analysis of Housing Cost and Supply Impacts of Sprinkler Ordinances at the Community Level,” did not reveal the enactment of sprinkler ordinances caused any detrimental effects on housing supply and costs. In the late 1980s, residential sprinkler ordinances were enacted in Prince George’s and Montgomery Counties. After each update of these municipalities’ sprinkler rules, there were no corresponding reductions in the number of single-family homes built in either county relative to their neighboring counties in Maryland and Virginia. In each instance, these municipalities actually realized a relatively larger increase in construction in the year after regulations became effective compared to the adjacent counties without sprinkler ordinances.

NAHB RESPONSE:

This isn’t particularly relevant or conclusive. The results are for two atypical counties in the Washington, D.C. metropolitan area where impacts of sprinklers were being obscured by many other things happening in the state of Maryland at about the same time: implementation of inclusionary zoning, seven-figure increments in impact fees, substantial new farmland protection legislation, the governor taking actions to stall large developments in the state, etc. With so many things in flux, it’s not surprising that a study would find it difficult to tease out a significant impact of any one factor in the area.

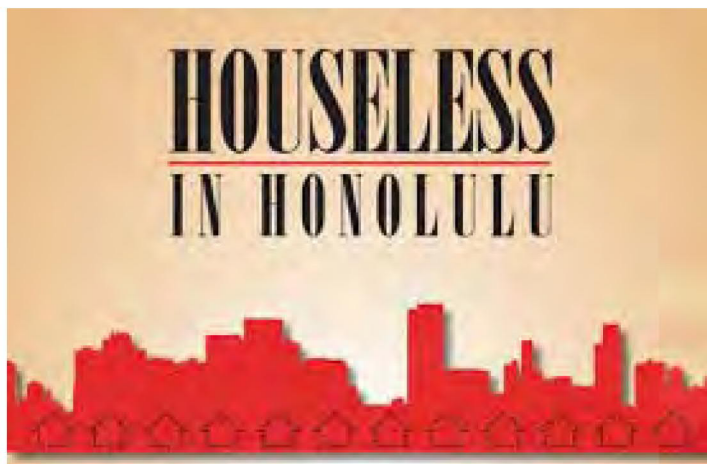

STATE FIRE COUNCIL RESPONSE:

The Fire Protection Research Foundation report in 2013 on “Home Fire Sprinkler Cost” found that many cities across the nation had a significant housing growth over the course of the study.

The Insurance Services Office, Inc. (ISO) is the leading supplier of underwriting information, advisory loss costs, supplementary rating information, and standardized policy language to insurers in all 50 states and the District of Columbia. The ISO offers between an 8% and 13% premium credit for a residential fire sprinkler system. Individual insurer programs may provide different credits. This could provide a substantial savings over the course of the 30-year mortgage. The ISO's standard homeowner policy forms provide coverage for accidental discharge or overflow of water from a fire sprinkler system at no extra charge.

The ISO Building Code Effectiveness Grading Schedule (BCEGS) is used to review public building code enforcement agencies and develop a classification that is provided as advisory information to insurers who may use it for insurance underwriting and rating. If the requirement of the International Residential Code for automatic fire sprinkler protection of residential dwellings is removed by legislation or local ordinance, BCEGS would not provide full recognition for adoption of the code.

NAHB RESPONSE:

"That many cities across the nation had a significant housing growth over the course of the study" is neither an accurate nor particularly relevant quote from the 2013 Fire Protection Research Foundation report.

The previous, 2008 Fire Protection Research Foundation Home Fire Sprinkler Cost Assessment report investigated insurance savings. It found that discount percentages ranged from 0 to 10% among all companies and agencies surveyed, with an average saving of \$22 off the annual premium. This is small relative to the up-front cost of a sprinkler system.

BIA HAWAII RESPONSE:

The cost of an automatic fire sprinkler system is comprised for the following two (2) basic components:

1. Cost to design and install the fire sprinkler system in the new dwelling from an existing water meter;
2. Cost of a new water meter depending on the flow requirements.

A summary of the overall cost of an automatic fire sprinkler system on a new home on Oahu are discussed in Section VIII of this report.

Position 6: Existing Water Service Meters Need to Be Upgraded to Accommodate Demand Created by a New Automatic Fire Sprinklers System.

STATE FIRE COUNCIL RESPONSE:

Honolulu presently requires ¾" water meters in residential homes that allow approximately 30 gallons per minute of water to enter the home. This is more than adequate by NFPA 13D standards to sufficiently provide water in the event two sprinkler heads are activated during a fire. Please note, neighbor islands would also require a ¾" water meter upgrade for residential sprinkler installations.

The city of Scottsdale found "2 or less sprinkler heads controlled more than 92 percent of the fires" that occurred in properties protected with fire sprinklers. The U.S. Fire Administration's Residential Fire Sprinkler Activation Report from 2003 to 2007 also found that more than 76% of residential fires were controlled with two or fewer sprinkler heads.



BIA HAWAII RESPONSE:

BIA Hawaii hired R.M. Towill Corporation, a local Engineering Company, to research and analyze the water meter requirements for each County in Hawaii. Based on their analysis, they found that in order to satisfy the potential building code requirement for a residential automatic fire sprinkler system, the flow demand for a single family dwelling increases by 31 gallons per minute (GPM) and for a duplex (2 family dwelling) it increases by 36 GPM. (See Exhibit D).

Based on consultation with the water supply agency in each county, this increase in flow necessitates either a larger water meter to be installed or, depending on the total flow (domestic plus fire flow) and the applicable county, a separate meter may be required. A backflow preventer must also be installed to protect the public water system. Additional installation costs associated with the larger meter will be incurred for items such as larger water laterals, water valves and higher facilities charges.

For Oahu the meter size is based on the higher water demand (fire flow or domestic). If the total domestic or fire flow is over 50 GPM, the Board of Water Supply (BWS) may require a second meter for the fire sprinklers. Water meter installation costs include the Water System Facilities (WSFC), which is based on fixture units (FU), and may also include a one-time fire charge.

County of Kauai, Department of Water (DOW), County of Maui, Department of Water Supply (DWS), and County of Hawaii, Department of Water Supply (Hawaii DWS) allow a larger water meter to be used to handle both the domestic and fire flow. The Facilities Reserve Charges (WFC) are based on the meter size and vary by County. If the optional second meter or detector check is used, a completely separate water line with a backflow preventer will be required. (See Exhibit E).

As an example, a 3 bedroom, 2 bath single family dwelling will use a 5/8" meter (3/4" for Oahu) without fire protection and will increase to a 1" meter with fire protection. For a 5 bedroom, 4-1/2 bath dwelling or a duplex will increase to a 1-1/2" meter. The following table summarizes these charges for BWS, DOW, DWS and Hawaii DWS (See Exhibit F for water meter flow capacities):

| Water System Facilities/Facilities Reserve Charges | | | | |
|---|-------------------------------------|----------------------|------------|------------|
| 3 bedroom, 2 bath single family dwelling (19.4 FU = 15 GPM) | | | | |
| | No Fire Sprinklers | With Fire Sprinklers | Difference | % Increase |
| County | 5/8" Meter (3/4" meter for Oahu) | 1" meter | | |
| Oahu | \$3,595.40* | \$10,007.82** | \$6,412 | 178.4% |
| Maui | \$12,060 | \$33,356 | \$21,296 | 176.6% |
| Kauai | \$14,155 | \$35,290 | \$21,135 | 149.3% |
| Hawaii Island | \$1,190 | \$13,750 | \$12,560 | 1,055% |

*Based on 19.4 FU (See Exhibit F for breakdown)

**Based on 54 FU (converted from 31 GPM for fire flow)

| Water System Facilities/Facilities Reserve Charges | | | | |
|---|-------------------------------------|--|------------|------------|
| 5 bedroom, 4-1/2 bath single family dwelling (31.5 FU = 20 GPM) | | | | |
| County | No Fire Sprinklers | With Fire Sprinklers | Difference | % Increase |
| | 5/8" meter (3/4" meter for Oahu) | 1-1/2" meter (3/4" & 1" meter for Oahu) | | |
| Oahu | \$5,837.90* | \$16,031.05** | \$10,193 | 174.6% |
| Maui | \$12,060 | \$71,948 | \$59,888 | 496.6% |
| Kauai | \$14,155 | \$70,580 | \$56,425 | 398.6% |
| Hawaii Island | \$1,190 | \$27,500 | \$26,310 | 2,211% |

*Based on 31.5 FU (See Exhibit F for breakdown)

**Based on 31.5 FU for 3/4" meter & 55 FU for 1" meter

| Water System Facilities/Facilities Reserve Charges | | | | |
|---|--|--|------------|------------|
| Duplex (2 family dwelling with 3 bedroom, 2 bath each) (38.8 FU = 30 GPM) | | | | |
| County | No Fire Sprinklers | With Fire Sprinklers | Difference | % Increase |
| | 3/4" meter (1" meter for Hawaii Island) | 1-1/2" meter (3/4" & 1" meter for Oahu) | | |
| Oahu | \$7,190.80* | \$20,163.90** | \$12,973 | 180.4% |
| Maui | \$18,884 | \$71,948 | \$53,064 | 281% |
| Kauai | \$21,170 | \$70,580 | \$49,410 | 233% |
| Hawaii Island | \$13,750 | \$27,500 | \$13,750 | 100% |

*Based on 38.8 FU (assumed doubled single family dwelling fixture units)

**Based on 38.8 FU for 3/4" meter & 70 FU for 1" meter

To further explain, for a typical 3 bedroom, 2 bath single family dwelling on Maui, the water meter would be sized for approximately 15 GPM, which equates to 19.4 FU (see Exhibit F). Adding 31 GPM for the fire sprinkler system increases the flow to 46 GPM and requires the water meter for a single family dwelling to increase two sizes larger from a 5/8" meter to a 1" meter (See Exhibit F for the breakdown of fixtures used for the 3 bedroom, 2 bath and 5 bedroom, 4-1/2 bath dwellings and for the capacity of each meter size).

The increase in WSFC/FRC for a typical 3 bedroom, 2 bath single family dwelling is lowest for Oahu because 5/8" meters are not allowed. A 5 bedroom, 4-1/2 bath dwelling is represented in the chart above because this type of dwelling will trigger an increased meter size to 1-1/2".

DOW allows a detector check to be used as an alternative to the second meter with a separate fire line. There is no FRC for a separate detector check but may have a one-time installation fee.

Monthly fees for fire service may be assessed and will vary by County and the size of the water line.

All counties require a backflow preventer to be installed between the water meter and the fire sprinkler system. The size and cost of the backflow preventer varies depending on the size of the water lateral. (See Exhibit G).

Pressure requirements may also increase with the addition of a fire sprinkler system. The associated costs to meet the higher pressure requirements will vary depending on the size and location of the dwelling. The impact from this would have to be determined on a case by case basis.

Based on communication with BWS, DOW, DWS and Hawaii DWS, since there is no current requirement for fire sprinklers on single family homes, their policies and requirements are not finalized and are subject to revisions if the policy changes.

VI. Additional Cost Estimates for New Home on Oahu, Maui or Hawaii

The following table provides a breakdown of how much more will be added to the cost of a house on Oahu, Maui or Hawaii if fire sprinklers are required in all new one and two family dwellings.

| Cost Breakdown | Oahu | Maui | Hawaii |
|--|--|--|-----------------------|
| Cost Analysis Fire Sprinkler Install | Two Story Home (Flag Lot) (Homeworks) | Cost Per Units--3 Plex, 2 Story (Stanford Carr) | Two Story Home |
| Size of Unit (SQFT) | 3,794.00 | 1,905.00 | 2,000.00 |
| DESCRIPTION | | | |
| Plans and Install of System | \$16,750.00 | \$26,388.33 | \$15,000.00 |
| Site Work (Trenching for new water line) | | | |
| Added Permit cost | \$68.94 | \$263.88 | \$135.00 |
| Fire Chief review(?) 10% of permit fee | \$539.00 | \$290.27 | \$1,500.00 |
| Plumber additional cost to upgrade to 1" line | \$1,400.00 | | \$2,745.00 |
| Plumber additional cost Regulator/backflow misc. | \$650.00 | | \$1,275.00 |
| Painter -additional masking L&M | \$425.00 | 250 | \$588.00 |
| Drywall-additional cost of install | \$400.00 | | \$588.00 |
| Electrician (wiring of bell/monitor stations) | \$300.00 | 1250 | \$588.00 |
| <i>Sum of hard costs</i> | <i>\$20,532.94</i> | <i>\$28,442.49</i> | <i>\$22,419.00</i> |
| G.C Overhead 15% | \$3,079.94 | \$1,422.12 | \$3,362.85 |
| G.C.Profit 5% | \$1,180.64 | \$1,422.12 | \$1,120.95 |
| GET | \$1,033.15 | \$1,473.61 | |
| Final Cost/Unit | \$25,826.67 | \$32,760.34 | \$26,902.80 |
| Cost per sq.ft. | \$ 6.81 | \$ 17.20 | \$13.45 |
| Water Meter Costs | | | |
| 2 Bath SFD (15 GPM to 31 GPM) | \$ 6,412.00 | | \$12,560.00 |
| 4 1/2 Bath SFD (20 GPM to 51 GPM) | \$10,193.00 | | \$26,310.00 |
| 2 Bath Duplex (Per Unit) | | \$26,532.00 | |
| Low Range | \$ 32,238.67 | \$ 59,292.34 | \$39,462.80 |
| High Range | \$ 36,019.67 | | \$ 53,212.80 |

With Hawaii having one of the highest housing prices in the nation, any increase in home prices here will make it more difficult for local families to afford a new home.

VII. Conclusions and Recommendations

Our study recognizes the points raised by the fire protection organizations, regarding the concerns to protect fire fights from new lightweight construction materials that have a faster burn rate than cut timber. This is one of the reasons for mandating the installation of automatic fire sprinkler systems in all new one and two family dwellings.

Our study also found that the Underwriter's Laboratory (2012) Report found that ". . . research demonstrated that a single layer of 1/2-inch gypsum wall board on the bottom of the unprotected floor assembly adds on average approximately 20 minutes to the time before collapse. This is a standard method of passive fire protection and applies to both legacy and modern construction. According to the UL study, firefighters can still expect close to 30 minutes of structural integrity in newer homes with a wood I joist floor with a layer of gypsum wallboard on the underside of the joists."

The difference in cost between a new automatic fire sprinkler system with associated increases in water meter size versus the cost of additional gypsum board to cover any exposed lightweight structural materials in new home construction is several thousand dollars.

We firmly believe that there are other, more cost effective methods that will not only protect fire fighters and homeowners but will not significantly increase the price of a new home in Hawaii.

As such, we believe that Section 3 (the Sunset provision) of Act 83, SLH 2012 be deleted or removed. This would prohibit the Counties from requiring the installation or retrofitting of automatic fire sprinklers or an automatic tire sprinkler system in any new construction of one or two family residential dwellings.

EXHIBIT "A"
EXCERPTS FROM 2012 IRC REGARDING FIRE SPRINKLERS

Section R313 of the 2012 International Residential Code (IRC) contains the following language:

SECTION R313 AUTOMATIC FIRE SPRINKLER SYSTEMS

R313.1 Townhouse automatic fire sprinkler systems.

An automatic residential fire sprinkler system shall be installed in townhouses.

Exception: An automatic residential fire sprinkler system shall not be required when additions or alterations are made to existing townhouses that do not have an automatic residential fire sprinkler system installed.

R313.1.1 Design and installation.

Automatic residential fire sprinkler systems for townhouses shall be designed and installed in accordance with Section P2904.

R313.2 One- and two-family dwellings automatic fire systems.

An automatic residential fire sprinkler system shall be installed in one- and two-family dwellings.

Exception: An automatic residential fire sprinkler system shall not be required for additions or alterations to existing buildings that are not already provided with an automatic residential sprinkler system.

R313.2.1 Design and installation.

Automatic residential fire sprinkler systems shall be designed and installed in accordance with Section P2904 or NFPA 13D.

A BILL FOR AN ACT

RELATING TO FIRE SPRINKLERS.

BE IT ENACTED BY THE LEGISLATURE OF THE STATE OF HAWAII:

1 SECTION 1. Chapter 46, Hawaii Revised Statutes, is amended
2 by adding a new section to be appropriately designated and to
3 read as follows:

4 "§46- Fire sprinklers; residences. No county shall
5 require the installation or retrofitting of automatic fire
6 sprinklers or an automatic fire sprinkler system in:

7 (1) Any new or existing detached one- or two-family
8 dwelling unit in a structure used only for residential
9 purposes; and

10 (2) Non-residential agricultural and aquacultural
11 buildings and structures located outside an urban
12 area;

13 provided that this section shall not apply to new homes that
14 require a variance from access road or fire fighting water
15 supply requirements."

16 SECTION 2. New statutory material is underscored.

17 SECTION 3. This Act shall take effect on July 1, 2012;
18 provided that on June 30, 2017, this Act shall be repealed.



Report Title:

Counties; Automatic Fire Sprinklers; Residences

Description:

Prohibits counties from requiring installation or retrofitting of automatic fire sprinklers in (1) new or existing one- or two-family dwelling units used only for residential purposes; and (2) non-residential agricultural and aquacultural buildings and structures located outside the urban area; provided that this does not apply to new homes that require a variance from access road or fire fighting water supply requirements.

Effective July 1, 2012. (SB2397 HD3)

The summary description of legislation appearing on this page is for informational purposes only and is not legislation or evidence of legislative intent.





HONOLULU COUNTY AFFORDABLE SALES PRICE GUIDELINES*

2016

COUNTY: **HONOLULU** FAMILY SIZE: **4 PERSON**

| | 50% | 60% | 70% | 80% | 90% | 100% | 110% | 120% | 130% | 140% |
|---------------------|-----------------|-----------------|-----------------|-----------------|-----------------|------------------|------------------|------------------|------------------|------------------|
| % of Median: | \$50,250 | \$60,300 | \$70,350 | \$80,400 | \$90,450 | \$100,500 | \$110,550 | \$120,600 | \$130,650 | \$140,700 |
| 0.00% | \$0 | \$0 | \$0 | \$0 | \$0 | \$0 | \$0 | \$0 | \$0 | \$0 |
| 3.00% | \$292,000 | \$350,400 | \$408,800 | \$467,200 | \$525,600 | \$584,000 | \$642,400 | \$700,800 | \$759,200 | \$817,600 |
| 3.58% | \$271,500 | \$325,800 | \$380,000 | \$434,300 | \$488,600 | \$542,900 | \$597,200 | \$651,500 | \$705,800 | \$760,100 |
| 3.50% | \$274,200 | \$329,000 | \$383,800 | \$438,700 | \$493,500 | \$548,300 | \$603,200 | \$658,000 | \$712,800 | \$767,700 |
| 3.75% | \$265,800 | \$319,000 | \$372,200 | \$425,300 | \$478,500 | \$531,700 | \$584,800 | \$638,000 | \$691,200 | \$744,300 |
| 4.00% | \$257,900 | \$309,400 | \$361,000 | \$412,600 | \$464,200 | \$515,700 | \$567,300 | \$618,900 | \$670,500 | \$722,000 |
| 4.25% | \$250,300 | \$300,300 | \$350,400 | \$400,400 | \$450,500 | \$500,500 | \$550,600 | \$600,600 | \$650,700 | \$700,700 |
| 4.50% | \$243,000 | \$291,600 | \$340,200 | \$388,800 | \$437,400 | \$486,000 | \$534,500 | \$583,100 | \$631,700 | \$680,300 |
| 4.75% | \$236,000 | \$283,200 | \$330,400 | \$377,600 | \$424,800 | \$472,000 | \$519,200 | \$566,400 | \$613,600 | \$660,800 |
| 5.00% | \$229,300 | \$275,200 | \$321,100 | \$366,900 | \$412,800 | \$458,700 | \$504,500 | \$550,400 | \$596,300 | \$642,100 |
| 5.25% | \$222,900 | \$267,500 | \$312,100 | \$356,700 | \$401,300 | \$445,900 | \$490,500 | \$535,100 | \$579,700 | \$624,300 |
| 5.50% | \$216,800 | \$260,200 | \$303,600 | \$346,900 | \$390,300 | \$433,700 | \$477,000 | \$520,400 | \$563,800 | \$607,100 |
| 5.75% | \$211,000 | \$253,200 | \$295,300 | \$337,500 | \$379,700 | \$421,900 | \$464,100 | \$506,300 | \$548,500 | \$590,700 |
| 6.00% | \$205,300 | \$246,400 | \$287,500 | \$328,500 | \$369,600 | \$410,700 | \$451,800 | \$492,800 | \$533,900 | \$575,000 |
| 6.25% | \$199,900 | \$239,900 | \$279,900 | \$319,900 | \$359,900 | \$399,900 | \$439,900 | \$479,900 | \$519,900 | \$559,900 |
| 6.50% | \$194,800 | \$233,700 | \$272,700 | \$311,600 | \$350,600 | \$389,600 | \$428,500 | \$467,500 | \$506,400 | \$545,400 |

*Please note that market sales prices may be lower than these sales price guidelines.

1. Based on **2016** Very low income levels established by HUD for various family sizes. See the "Income Schedule by Family Size" table for a more detailed explanation.
2. Mortgage term: **30 years** 360
3. Housing Expense of: **28.00%**
4. Down Payment of: **5.00%**



Randolph H. Murayama & Associates
Consulting Engineers— Mechanical
1267 Young Street
Honolulu, Hawaii 96814
Phone: (808) 593-9360 Fax: (808) 591-9362

R. M. Towill Corporation
2024 N. King St., Suite 200
Honolulu, Hawaii 96819

October 25, 2016

REFERENCE: BIA Fire Flow Study
ATTENTION: Stacy Armstrong

Dear Ms. Armstrong:

We have concluded our evaluation of the fire flow requirements associated with the potential adoption by the local Authorities having Jurisdiction (AHJ) requiring automatic fire sprinkler systems for new construction residential properties. The evaluation was limited to single and two family dwellings as determined by NFPA 13D, 2010.

The International Residential Code (IRC 2006) as adopted by the State of Hawaii, Appendix P, does not require automatic fire sprinkler unless specifically adopted as part of the local ordinances. Should this be adopted, it requires the automatic fire sprinkler system to be installed in accordance with Section 903.3.1 of the International Building Code (IBC 2006). The IBC 2006 requires that the installation of the automatic fire sprinkler system be installed per the currently adopted National Fire Protection Association (NFPA 13D, 2010).

NFPA 13D, 2010, requires that flow requirements for residential properties of single and two family dwellings be sized for a maximum of a single head providing 18 gpm and a second head 13 gpm to the greatest hydraulic demand. Should the two family dwelling be served from a common water supply, NFPA 13D (2010) requires an additional 5 gpm added to the sprinkler demand, making the maximum requirement 36 gpm water flow. Pressure required would depend on the size of the dwelling since the requirement is for the greatest hydraulic demand. We expect the pressure requirements to be in the range of 40 psi to 60 psi depending on the size of the dwelling.

The requirement to have an automatic fire sprinkler system lies in the individual Counties (City and County of Honolulu, Maui County, Kauai County and Hawaii County) adopting Appendix P of the IRC 2006. Any county doing so, will need to generally follow the listed trail of Codes as we have outlined.

Attached are documentation from IRC 2006 – Appendix P, IBC 2006-Chapter 903.3.1, and NFPA 2010 – 8.1 Design Criteria.

If you have any questions, please call me at 593-9360, ext. 109.

Sincerely,

Eric S. Nakagawa, P.E., CxA

Appendix P: Fire Sprinkler System

The provisions contained in this appendix are not mandatory unless specifically referenced in the adopting ordinance.

AP101 Fire sprinklers. An approved automatic fire sprinkler system shall be installed in new one- and two-family dwellings and townhouses in accordance with Section 903.3.1 of the *International Building Code*.

linear feet (15 240 mm), or fraction thereof, of exterior wall in the story on at least one side.

2. Openings entirely above the adjoining ground level totaling at least 20 square feet (1.86 m²) in each 50 linear feet (15 240 mm), or fraction thereof, of exterior wall in the story on at least one side.

[F] 903.2.10.1.1 Opening dimensions and access. Openings shall have a minimum dimension of not less than 30 inches (762 mm). Such openings shall be accessible to the fire department from the exterior and shall not be obstructed in a manner that fire fighting or rescue cannot be accomplished from the exterior.

[F] 903.2.10.1.2 Openings on one side only. Where openings in a story are provided on only one side and the opposite wall of such story is more than 75 feet (22 860 mm) from such openings, the story shall be equipped throughout with an approved automatic sprinkler system, or openings as specified above shall be provided on at least two sides of the story.

[F] 903.2.10.1.3 Basements. Where any portion of a basement is located more than 75 feet (22 860 mm) from openings required by Section 903.2.10.1, the basement shall be equipped throughout with an approved automatic sprinkler system.

[F] 903.2.10.2 Rubbish and linen chutes. An automatic sprinkler system shall be installed at the top of rubbish and linen chutes and in their terminal rooms. Chutes extending through three or more floors shall have additional sprinkler heads installed within such chutes at alternate floors. Chute sprinklers shall be accessible for servicing.

[F] 903.2.10.3 Buildings 55 feet or more in height. An automatic sprinkler system shall be installed throughout buildings with a floor level having an occupant load of 30 or more that is located 55 feet (16 764 mm) or more above the lowest level of fire department vehicle access.

Exceptions:

1. Airport control towers.
2. Open parking structures.
3. Occupancies in Group F-2.

[F] 903.2.11 During construction. Automatic sprinkler systems required during construction, alteration and demolition operations shall be provided in accordance with the *International Fire Code*.

[F] 903.2.12 Other hazards. Automatic sprinkler protection shall be provided for the hazards indicated in Sections 903.2.12.1 and 903.2.12.2.

[F] 903.2.12.1 Ducts conveying hazardous exhausts. Where required by the *International Mechanical Code*, automatic sprinklers shall be provided in ducts conveying hazardous exhaust, or flammable or combustible materials.

Exception: Ducts in which the largest cross-sectional diameter of the duct is less than 10 inches (254 mm).

[F] 903.2.12.2 Commercial cooking operations. An automatic sprinkler system shall be installed in commercial kitchen exhaust hood and duct system where an automatic sprinkler system is used to comply with Section 904.

[F] 903.2.13 Other required suppression systems. In addition to the requirements of Section 903.2, the provisions indicated in Table 903.2.13 also require the installation of a suppression system for certain buildings and areas.

**[F] TABLE 903.2.13
ADDITIONAL REQUIRED SUPPRESSION SYSTEMS**

| SECTION | SUBJECT |
|------------------|--|
| 402.8 | Covered malls |
| 403.2, 403.3 | High-rise buildings |
| 404.3 | Atriums |
| 405.3 | Underground structures |
| 407.5 | Group I-2 |
| 410.6 | Stages |
| 411.4 | Special amusement buildings |
| 412.2.5, 412.2.6 | Aircraft hangars |
| 415.6.2.4 | Group H-2 |
| 416.4 | Flammable finishes |
| 417.4 | Drying rooms |
| 507 | Unlimited area buildings |
| 508.2 | Incidental use areas |
| 1025.6.2.3 | Smoke-protected assembly seating |
| IFC | Sprinkler system requirements as set forth in Section 903.2.13 of the <i>International Fire Code</i> |

[F] 903.3 Installation requirements. Automatic sprinkler systems shall be designed and installed in accordance with Sections 903.3.1 through 903.3.7.

[F] 903.3.1 Standards. Sprinkler systems shall be designed and installed in accordance with Section 903.3.1.1, 903.3.1.2 or 903.3.1.3.

[F] 903.3.1.1 NFPA 13 sprinkler systems. Where the provisions of this code require that a building or portion thereof be equipped throughout with an automatic sprinkler system in accordance with this section, sprinklers shall be installed throughout in accordance with NFPA 13 except as provided in Section 903.3.1.1.1.

[F] 903.3.1.1.1 Exempt locations. Automatic sprinklers shall not be required in the following rooms or areas where such rooms or areas are protected with an approved automatic fire detection system, in accordance with Section 907.2, that will respond to visible or invisible particles of combustion. Sprinklers shall not be omitted from any room merely because it is

damp, of fire-resistance-rated construction or contains electrical equipment.

1. Any room where the application of water, or flame and water, constitutes a serious life or fire hazard.
2. Any room or space where sprinklers are considered undesirable because of the nature of the contents, when approved by the fire code official.
3. Generator and transformer rooms separated from the remainder of the building by walls and floor/ceiling or roof/ceiling assemblies having a fire-resistance rating of not less than 2 hours.
4. In rooms or areas that are of noncombustible construction with wholly noncombustible contents.

[F] 903.3.1.2 NFPA 13R sprinkler systems. Where allowed in buildings of Group R, up to and including four stories in height, automatic sprinkler systems shall be installed throughout in accordance with NFPA 13R.

[F] 903.3.1.2.1 Balconies and decks. Sprinkler protection shall be provided for exterior balconies, decks and ground floor patios of dwelling units where the building is of Type V construction. Sidewall sprinklers that are used to protect such areas shall be permitted to be located such that their deflectors are within 1 inch (25 mm) to 6 inches (152 mm) below the structural members and a maximum distance of 14 inches (356 mm) below the deck of the exterior balconies and decks that are constructed of open wood joist construction.

[F] 903.3.1.3 NFPA 13D sprinkler systems. Where allowed, automatic sprinkler systems in one- and two-family dwellings shall be installed throughout in accordance with NFPA 13D.

[F] 903.3.2 Quick-response and residential sprinklers. Where automatic sprinkler systems are required by this code, quick-response or residential automatic sprinklers shall be installed in the following areas in accordance with Section 903.3.1 and their listings:

1. Throughout all spaces within a smoke compartment containing patient sleeping units in Group I-2 in accordance with this code.
2. Dwelling units, and sleeping units in Group R and I-1 occupancies.
3. Light-hazard occupancies as defined in NFPA 13.

[F] 903.3.3 Obstructed locations. Automatic sprinklers shall be installed with due regard to obstructions that will delay activation or obstruct the water distribution pattern. Automatic sprinklers shall be installed in or under covered kiosks, displays, booths, concession stands, or equipment that exceeds 4 feet (1219 mm) in width. Not less than a 3-foot

(914 mm) clearance shall be maintained between automatic sprinklers and the top of piles of combustible fibers.

Exception: Kitchen equipment under exhaust hoods protected with a fire-extinguishing system in accordance with Section 904.

[F] 903.3.4 Actuation. Automatic sprinkler systems shall be automatically actuated unless specifically provided for in this code.

[F] 903.3.5 Water supplies. Water supplies for automatic sprinkler systems shall comply with this section and the standards referenced in Section 903.3.1. The potable water supply shall be protected against backflow in accordance with the requirements of this section and the *International Plumbing Code*.

[F] 903.3.5.1 Domestic services. Where the domestic service provides the water supply for the automatic sprinkler system, the supply shall be in accordance with this section.

[F] 903.3.5.1.1 Limited area sprinkler systems. Limited area sprinkler systems serving fewer than 20 sprinklers on any single connection are permitted to be connected to the domestic service where a wet automatic standpipe is not available. Limited area sprinkler systems connected to domestic water supplies shall comply with each of the following requirements:

1. Valves shall not be installed between the domestic water riser control valve and the sprinklers.

Exception: An approved indicating control valve supervised in the open position in accordance with Section 903.4.

2. The domestic service shall be capable of supplying the simultaneous domestic demand and the sprinkler demand required to be hydraulically calculated by NFPA 13, NFPA 13R or NFPA 13D.

[F] 903.3.5.1.2 Residential combination services. A single combination water supply shall be allowed provided that the domestic demand is added to the sprinkler demand as required by NFPA 13R.

[F] 903.3.5.2 Secondary water supply. A secondary on-site water supply equal to the hydraulically calculated sprinkler demand, including the hose stream requirement, shall be provided for high-rise buildings in Seismic Design Category C, D, E or F as determined by this code. The secondary water supply shall have a duration of not less than 30 minutes as determined by the occupancy hazard classification in accordance with NFPA 13.

Exception: Existing buildings.

5.2.10 Other joining methods investigated for suitability in automatic sprinkler installations and listed for this service shall be permitted.

5.3* Underground Pipe. Any type of pipe or tube acceptable under the applicable plumbing code for underground supply pipe shall be acceptable as underground supply for fire sprinkler system when installed between the point of connection and the system riser.

5.4 Pre-engineered Systems. Where listed pre-engineered systems are installed, they shall be installed within the limitations that have been established by the testing laboratories.

Chapter 6 Water Supply

6.1 General Provisions.

6.1.1 Every automatic sprinkler system shall have at least one automatic water supply.

6.1.2 Where stored water is used as the sole source of supply, the minimum quantity shall equal the water demand rate times 10 minutes unless permitted otherwise by 6.1.3.

6.1.3 Where stored water is used as the sole source of supply, the minimum quantity shall be permitted to equal the two sprinkler water demand rate times 7 minutes where dwelling units meet the following criteria:

- (1) One story in height
- (2) Less than 2000 ft² (186 m²) in area

6.1.4 The stored water requirement of 6.1.2 or 6.1.3 shall be permitted to be a combination of the water in the well (including the refill rate) plus the water in the holding tank if such tank can supply the sprinkler system.

6.2* Water Supply Sources. The following water supply sources shall be considered to be acceptable by this standard:

- (1) A connection to a reliable waterworks system with or without an automatically operated pump
- (2) An elevated tank
- (3) A pressure tank designed to American Society of Mechanical Engineers (ASME) standards for a pressure vessel with a reliable pressure source
- (4) A stored water source with an automatically operated pump
- (5) A well with a pump of sufficient capacity and pressure to meet the sprinkler system demand

6.2.1* Prior to system acceptance, a system utilizing a pump shall be tested by opening the drain/test connection.

6.2.1.1 The pump shall sense the flow, turn on, and flow water for the required duration of 6.1.2 or 6.1.3 without interruption.

6.2.2 Where a pump and tank is the source of supply for a fire sprinkler system but is not a portion of the domestic water system, the following shall be met:

- (1) A test connection shall be provided downstream of the pump that creates a flow of water equal to the smallest sprinkler on the system. The connection shall return water to the tank.
- (2) Pump motors using ac power shall be connected to a 240 V normal circuit.
- (3) Any disconnecting means for the pump shall be approved.
- (4) A method for refilling the tank shall be piped to the tank.
- (5) A method of seeing the water level in the tank shall be provided without having to open the tank.
- (6) The pump shall not be permitted to sit directly on the floor.

6.2.3* Where more than one dwelling unit is served by the same water supply pipe, each dwelling unit shall have an individual control valve that serves the fire sprinkler system in that dwelling unit and the owner shall have access to the valve that controls the sprinkler system in their unit.

6.2.3.1 The control valve shall be permitted to serve the domestic water supply.

6.2.3.2 In the situation addressed by 6.2.3, no valve controlling the sprinkler system in a unit shall be located in another unit.

6.3* Multipurpose Piping System.

6.3.1 A multipurpose piping system shall be installed in accordance with 6.3.2 through 6.5.4.

6.3.2 Multipurpose piping systems shall be approved by the local plumbing or health authority.

6.3.3 All piping in the system supplying sprinklers shall be listed and conform to the piping specifications of this standard.

6.3.3.1 Piping connected to the system that supplies only plumbing fixtures shall comply with local plumbing and health authority requirements but is not required to be listed.

6.4 Manufactured Home Water Supply. For sprinklered buildings manufactured off-site, the minimum pressure needed to satisfy the system design criteria on the system side of the meter shall be specified on a data plate by the manufacturer.

6.5 Common Supply Pipes.

6.5.1 Where common supply pipes serve both fire sprinkler and domestic use, they shall comply with 6.5.2 through 6.5.4.

6.5.2 In common water supply connections serving more than one dwelling unit, 5 gpm (19 L/min) shall be added to the sprinkler system demand to determine the size of common piping and the size of the total water supply requirements where no provision is made to prevent flow into the domestic water system upon operation of a sprinkler.

6.5.3 A warning sign, with minimum ¼ in. letters, shall be affixed adjacent to the main shutoff valve and shall state the following:

WARNING: The water system for this home supplies fire sprinklers that require certain flows and pressures to fight a fire. Devices that restrict the flow or decrease the pressure or automatically shut off the water to the fire sprinkler system, such as water softeners, filtration systems, and automatic shutoff valves, shall not be added to this system without a review of the fire sprinkler system by a fire protection specialist. Do not remove this sign.

6.5.4 Where water treatment and filtration are installed, one of the following conditions shall be met:

- (1) The flow restriction and pressure loss through the water treatment equipment shall be taken into account in the hydraulic calculations.
- (2) An automatic bypass shall be installed around the water treatment equipment that directs all water directly to the system.

Chapter 7 Installation

7.1 Valves.

7.1.1 A single control valve arranged to shut off both the domestic system and the sprinkler system shall be installed unless a separate shutoff valve for the sprinkler system is installed in accordance with 7.1.2.

7.5.6* Painting and Ornamental Finishes. Sprinklers shall not be painted or enameled unless applied by the manufacturer and the sprinkler has been listed with such finishes.

7.5.7 Escutcheon Plates. Where nonmetallic sprinkler ceiling plates (escutcheons) or recessed escutcheons (metallic or nonmetallic) are used, they shall be listed based on testing of the assembly as a residential sprinkler.

7.5.8 Solvent Cement. Where solvent cement is used as the pipe and fittings bonding agent, sprinklers shall not be installed in the fittings prior to the fittings being cemented in place.

7.6* Alarms. Local waterflow alarms shall be provided on all sprinkler systems in homes not equipped with smoke alarms or smoke detectors in accordance with *NFPA 72, National Fire Alarm and Signaling Code*.

7.7 Attics. When nonmetallic piping is installed in attics, adequate insulation shall be provided on the attic side of the piping to avoid exposure of the piping to temperatures in excess of the pipe's rated temperature.

Chapter 8 System Design

8.1 Design Criteria.

8.1.1 Design Discharge.

8.1.1.1 Sprinklers That Are Not Listed with Specific Discharge Criteria.

8.1.1.1.1 The system shall provide a discharge of not less than 13 gpm (49 L/min) per sprinkler simultaneously to all of the design sprinklers.

8.1.1.1.2 The system shall provide a discharge of not less than 18 gpm (68 L/min) to any sprinkler in the system.

8.1.1.2* Sprinklers That Are Listed with Specific Discharge Criteria.

8.1.1.2.1 The system shall provide at least the flow required for the multiple and single sprinkler operating criteria specified by the sprinkler listing.

8.1.1.2.2* The system shall provide at least the flow required to produce a minimum discharge density of 0.05 gpm/ft² (2.04 mm/min) to the design sprinklers.

8.1.2* Number of Design Sprinklers. The number of design sprinklers under flat, smooth, horizontal ceilings shall include all sprinklers within a compartment, up to a maximum of two sprinklers, that require the greatest hydraulic demand.

8.1.3 Sprinkler Coverage.

8.1.3.1 Residential Sprinklers.

8.1.3.1.1 Sprinklers shall be installed in accordance with their listing where the type of ceiling configuration is referenced in the listing.

8.1.3.1.2* Where construction features or other special conditions exist that are outside the scope of sprinkler listings, listed sprinklers shall be permitted to be installed beyond their listing limitations.

8.1.3.1.3 Sloped Ceilings.

8.1.3.1.3.1 Where the ceiling is sloped, the maximum *S* dimension shall be measured along the slope of the ceiling to the next sprinkler, as shown in Figure 8.1.3.1.3.1.

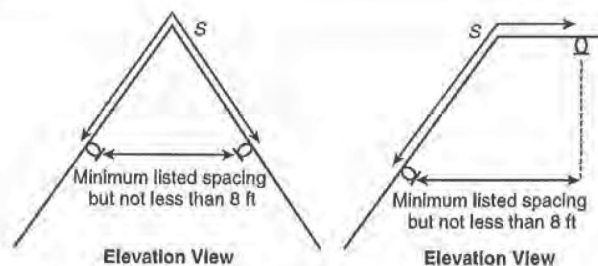

FIGURE 8.1.3.1.3.1 Measuring *S* Dimension.

8.1.3.1.3.2 The sprinklers shall maintain the minimum listed spacing, but no less than 8 ft (2.44 m), measured in the plan view from one sprinkler to another, as shown in Figure 8.1.3.1.3.1.

8.1.3.2 Nonresidential Sprinklers. Sprinklers other than residential sprinklers shall be installed in accordance with the coverage criteria specified by NFPA 13, *Standard for the Installation of Sprinkler Systems*.

8.1.4 Operating Pressure. The minimum operating pressure of any sprinkler shall be the higher of the minimum operating pressure specified by the listing or 7 psi (0.5 bar).

8.2 Position of Sprinklers.

8.2.1 Residential Pendent and Upright Sprinklers.

8.2.1.1 Pendent and upright sprinklers that have not been listed with specific positioning criteria shall be positioned so that the deflectors are within 1 in. to 4 in. (25.4 mm to 102 mm) from the ceiling unless otherwise permitted by 8.2.1.3.

8.2.1.2 Pendent and upright sprinklers that have been listed with specific positioning criteria shall be positioned in accordance with their listing unless permitted otherwise by 8.2.1.3.

8.2.1.3 Pendent and upright sprinklers in closets shall be permitted to be installed within 12 in. (305 mm) of the ceiling in order to avoid obstructions near the ceiling.

8.2.2 Residential Sidewall Sprinklers.

8.2.2.1 Sidewall sprinklers that have not been listed with specific positioning criteria shall be positioned so that the deflectors are within 4 in. to 6 in. (102 mm to 152 mm) from the ceiling.

8.2.2.2 Sidewall sprinklers that have been listed with specific positioning criteria shall be installed in accordance with their listing.

8.2.3 Nonresidential Sprinklers. Sprinklers other than residential sprinklers shall be positioned in accordance with the positioning criteria specified by NFPA 13, *Standard for the Installation of Sprinkler Systems*.

8.2.4 In basements where ceilings are not required for the protection of piping or where metallic pipe is installed, residential sprinklers shall be permitted to be positioned in a manner that anticipates future installation of a finished ceiling.

8.2.5* Obstructions to Residential Sprinklers.

8.2.5.1 Closets. In all closets, including those closets housing mechanical equipment, that are not larger than 400 ft³ (11.3 m³) in size, a single sprinkler at the highest ceiling space in the closet shall be sufficient without regard to obstructions.

CITY AND COUNTY OF HONOLULU
REVISION TO THE SCHEDULE OF RATES AND CHARGES
FOR THE FURNISHING OF WATER AND WATER SERVICE
 Amended by Resolution No. 780, 2007, effective July 1, 2007

Printed: 5/1/2013

| <u>WATER SYSTEM FACILITIES CHARGES</u> | | |
|--|-----------------|-----------------|
| Per Fixture Unit (F.U.) | | |
| | July 1, 2014 | July 1, 2015 |
| <u>RESIDENTIAL - (Minimum 20 F.U.)</u> | | |
| Single Family Residential | | |
| Resource Development | \$80.04 | \$80.04 |
| Transmission | 37.87 | 37.87 |
| Daily Storage | 67.42 | 67.42 |
| Total | \$185.33 | \$185.33 |
| MultiFamily - Low-Rise | | |
| Resource Development | \$117.14 | \$117.14 |
| Transmission | 55.46 | 55.46 |
| Daily Storage | 98.67 | 98.67 |
| Total | \$271.27 | \$271.27 |
| MultiFamily - High-Rise | | |
| Resource Development | \$88.14 | \$88.14 |
| Transmission | 41.73 | 41.73 |
| Daily Storage | 74.25 | 74.25 |
| Total | \$204.12 | \$204.12 |
| <u>NON-RESIDENTIAL - (Commercial, Industrial, Hotel, Parks & Schools)</u> | | |
| <50 F.U. (Minimum 20 F.U.) | | |
| Resource Development | \$257.74 | \$257.74 |
| Transmission | 130.65 | 130.65 |
| Daily Storage | 232.46 | 232.46 |
| Total | \$620.85 | \$620.85 |
| >50 F.U. | | |
| Resource Development | \$95.15 | \$95.15 |
| Transmission | 45.04 | 45.04 |
| Daily Storage | 80.10 | 80.10 |
| Total | \$220.29 | \$220.29 |
| <u>AGRICULTURE - (By Meter Size)</u> | | |
| 5/8" Meter | | |
| Resource Development | \$2,081.08 | \$2,081.08 |
| Transmission | 984.64 | 984.64 |
| Daily Storage | 1,752.86 | 1,752.86 |
| Total | \$4,818.58 | \$4,818.58 |
| 3/4" Meter | | |
| Resource Development | \$2,881.05 | \$2,881.05 |
| Transmission | 1,363.35 | 1,363.35 |
| Daily Storage | 2,427.04 | 2,427.04 |
| Total | \$6,671.44 | \$6,671.44 |
| 1" Meter | | |
| Resource Development | \$4,721.68 | \$4,721.68 |
| Transmission | 2,234.38 | 2,234.38 |
| Daily Storage | 3,977.65 | 3,977.65 |
| Total | \$10,933.71 | \$10,933.71 |
| 1-1/2" Meter | | |
| Resource Development | \$12,804.55 | \$12,804.55 |
| Transmission | 6,059.34 | 6,059.34 |
| Daily Storage | 10,786.86 | 10,786.86 |
| Total | \$29,650.75 | \$29,650.75 |
| 2" Meter | | |
| Resource Development | \$28,014.53 | \$28,014.53 |
| Transmission | 13,254.81 | 13,254.81 |
| Daily Storage | 23,596.26 | 23,596.26 |
| Total | \$64,865.60 | \$64,865.60 |

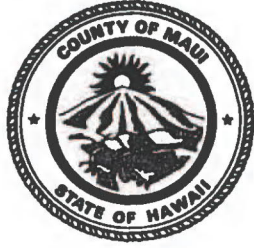

COUNTY OF MAUI

REVENUES - FEES, RATES, ASSESSMENTS AND TAXES

APPENDIX B

FISCAL YEAR JULY 1, 2016 TO JUNE 30, 2017

DEPARTMENT OF WATER SUPPLY
WATER FUND

| | | | |
|------|--|--|-----------------------|
| 3475 | Water Service Rates General Water Consumers | Water service charges to Single-family dwellings, single-family and accessory dwellings with 5/8" meters (Monthly): | Charter 8- 11.4(2) |
| | | Per 1,000 Gallons | |
| | | 0-5,000 gallons\$2.00 | |
| | | 5,001-15,000 gallons\$3.80 | |
| | | 15,001-35,000 gallons\$5.70 | |
| | | ≥35,001 gallons\$6.35 | |

COUNTY OF MAUI
REVENUES - FEES, RATES, ASSESSMENTS AND TAXES

| ACCOUNT | REVENUE SOURCE | FEE, RATE, ASSESSMENT OR TAX | HRS | COUNTY CODE | ORDINANCE |
|---------|----------------|------------------------------|-----|-------------|-----------|
|---------|----------------|------------------------------|-----|-------------|-----------|

**DEPARTMENT OF WATER SUPPLY
WATER FUND (Cont.)**

Water Shortage Rates

| | Stage 1 | Stage 2 | Stage 3 |
|----------------------------|---------|---------|---------|
| Per 1,000 Gallons | | | |
| 0 - 5,000 gallons..... | \$2.00 | 2.00 | 2.00 |
| 5,001-15,000 gallons..... | 3.80 | 3.80 | 3.80 |
| 15,001-35,000 gallons..... | 5.70 | 7.10 | 8.50 |
| ≥35,001 gallons..... | 6.35 | 9.50 | 11.10 |

Water service charges to All Other General Water Consumers (Monthly):

Per 1,000 Gallons

| | |
|---------------------------|--------|
| 0 - 5,000 gallons..... | \$2.00 |
| 5,001-15,000 gallons..... | \$3.80 |
| ≥ 15,001 gallons..... | \$5.70 |

Water Shortage Rates

| | Stage 1 | Stage 2 | Stage 3 |
|---------------------------|---------|---------|---------|
| Per 1,000 Gallons | | | |
| 0 - 5,000 gallons..... | \$2.00 | 2.00 | 2.00 |
| 5,001-15,000 gallons..... | 3.80 | 3.80 | 3.80 |
| ≥ 15,001 gallons..... | 5.70 | 7.10 | 8.50 |

In addition to the above water service charges, there is a monthly service charge by meter size

| Size of Meter | Per Meter/Month |
|----------------------|-----------------|
| 5/8 inch (02)..... | \$19.25 |
| 3/4 inch (03)..... | \$31.00 |
| 1 inch (04)..... | \$46.00 |
| 1-1/2 inch (06)..... | \$88.00 |
| 2 inch (07)..... | \$137.00 |
| 3 inch (09)..... | \$242.00 |
| 4 inch (12)..... | \$420.00 |
| 6 inch (15)..... | \$770.00 |
| 8 inch (18)..... | \$1,215.00 |

3475 Temporary Meter Charges

The meter service charge for all temporary meters shall be equal to the charge for 3-inch meter. In addition, there shall be an installation and conservation meter charge. The installation charge shall be based on the cost of installation and will be determined case by case. The conservation charge shall be 1.5 times the "general" water service rate.

Charter 8-11.4(2)

3477 Water Service Rates - Agricultural Consumers

Agriculture and non-potable water service charges (Monthly):

Charter 8-11.4(2)

Agricultural Rates

Per 1,000 Gallons

| | |
|---------------------------|--------|
| 0 - 5,000 gallons..... | \$2.00 |
| 5,001-15,000 gallons..... | \$3.80 |
| ≥ 15,001 gallons..... | \$1.10 |

Water Shortage Rates

| | Stage 1 | Stage 2 | Stage 3 |
|---------------------------|---------|---------|---------|
| Per 1,000 Gallons | | | |
| 0 - 5,000 gallons..... | \$2.00 | 2.00 | 2.00 |
| 5,001-15,000 gallons..... | 3.80 | 3.80 | 3.80 |
| ≥ 15,001 gallons..... | 1.10 | 1.20 | 1.30 |

Non-Potable Rates

| | |
|----------------|--------|
| All usage..... | \$1.00 |
|----------------|--------|

COUNTY OF MAUI
REVENUES - FEES, RATES, ASSESSMENTS AND TAXES

| ACCOUNT | REVENUE SOURCE | FEE, RATE, ASSESSMENT OR TAX | HRS | COUNTY CODE | ORDNANCE |
|---------|----------------|------------------------------|-----|-------------|----------|
|---------|----------------|------------------------------|-----|-------------|----------|

**DEPARTMENT OF WATER SUPPLY
WATER FUND (Cont.)**

In addition to the above water service charges, there is a monthly service charge by meter size:

| Size of Meter | Per Meter/Month |
|-----------------|-----------------|
| 5/8 inch (02) | \$19.25 |
| 3/4 inch (03) | \$31.00 |
| 1 inch (04) | \$46.00 |
| 1-1/2 inch (06) | \$88.00 |
| 2 inch (07) | \$137.00 |
| 3 inch (09) | \$242.00 |
| 4 inch (12) | \$420.00 |
| 6 inch (15) | \$770.00 |
| 8 inch (18) | \$1,215.00 |

3480 Fire Water Service Rates

| | Per Month |
|---|-----------|
| Hydrants (per hydrant) | \$3.50 |
| Standpipes (per standpipe) | \$2.00 |
| Private fire systems (per inch diameter of feeder main) | \$2.75 |

Water service usage as measured by detector check meters in private fire systems shall be billed at 35 times the meter reading.

Water service usage as measured by fire meters reading the full flow shall be billed at 1.5 times the total reading. If water usage can be shown to result from a fire, there shall be no charge other than the private fire system charge.

3481 Restoration Charge

| | | | |
|---|-------|-------|---|
| Restoration of Water Service for locked meter | \$100 | 54-33 | Department of Water Supply Rules and Regulations 3-11 |
|---|-------|-------|---|

Installation Charges

| | | | |
|--|-------|-------|--------------|
| New Installation of 5/8" meter: Existing cast iron meter box and fittings | \$160 | 54-33 | 14,04,040(B) |
|--|-------|-------|--------------|

| | |
|--|-------|
| New installation of 3/4" and 1" meters: Existing cast iron meter box and fittings | \$230 |
|--|-------|

Flat charge applies only on installations requested by consumers at locations with existing service lateral

Temporary construction meter installations are subject to the "Applications and Agreement of Terms & Conditions for a Permit to use a Fire Hydrant or Standpipe for a Temporary Meter" \$485

Replacing damaged or missing transponder \$160

Replacing damaged or missing meter, cost of meter, plus 20% plus cost of materials. By Size

Replacement of Ball Valves \$260

All jobs will require a cash deposit and upon completion, the customer will be billed or refunded the difference between the deposit and actual cost to do the job.

Charges Billed on Actual Cost

| | Deposit |
|---|---------|
| All Meter upgrades, reinstallations, and relocations (minimum charge - \$160) | \$1,000 |
| Installation of greater than 1" permanent meters (minimum charge - \$160) | \$1,000 |

COUNTY OF MADRID
REVENUES - FEES, RATES, ASSESSMENTS AND TAXES

| ACCOUNT | REVENUE SOURCE | FEE, RATE, ASSESSMENT OR TAX | HRS | COUNTY CODE | ORDINANCE |
|---------|----------------|------------------------------|-----|-------------|-----------|
|---------|----------------|------------------------------|-----|-------------|-----------|

**DEPARTMENT OF WATER SUPPLY
WATER FUND (Cont.)**

Installation of service lateral (1" or 1-1/4") requiring tapping the mainline (minimum charge \$160):

| | |
|-----------------------------|---------|
| Same side of road | \$1,500 |
| Opposite side of road | \$2,100 |
| Paving costs | \$2,100 |

Corporation Tap - Wet tap existing waterline with corporation stop (minimum charge \$160)

| | |
|--|-------|
| | \$360 |
|--|-------|

Tap-in - Wet tap existing waterline with tapping sleeve and gate valve (minimum charge \$160):

Sizes

| | |
|-----------------------|-------|
| 4", 6", 8", 12" | \$900 |
|-----------------------|-------|

Tie-in - Removal of plug or cap from existing waterline and connect new waterline (minimum charge \$160):

Sizes

| | |
|--------------------|---------|
| 4", 6", 8" | \$900 |
| 12" and over | \$1,200 |

Cut-in - Installation of fitting and/or valve in existing waterline (minimum charge \$160):

Sizes

| | |
|----------------------|---------|
| 4", 6", 8" | \$1,000 |
| Using A/C pipe | \$1,500 |
| 12" and over | \$1,500 |
| Using A/C pipe | \$2,000 |

There will be a minimum charge of \$100 for all jobs billed at actual cost.

Overtime Work - Additional Deposit

| | |
|--|---------|
| | \$1,200 |
|--|---------|

The contractor shall furnish all fittings, pipes, and valves as well as all excavation, back fill work and reaction blocks for connections. The contractor shall have equipment and equipment operator at the job site to lower pipe, fittings, valves or tapping machine into the trench. A licensed DSO (Distribution System Operator) must be present on the job site. A higher deposit may be required for complex connections or hazardous conditions.

In addition to these charges, labor cost and other incidental supplies shall be computed and billed to the customer upon job completion and shall be based on actual labor time, rate and cost of incidental supplies.

| Labor (includes overhead) | Per Hour |
|---------------------------|----------|
| Job Costing | \$55.83 |
| Overtime | \$83.76 |

| | |
|------------------|----------|
| Inspection | \$68.94 |
| Overtime | \$103.41 |

Materials (includes 20% stores expense) (see as follows)

Equipment (see as follows)

| | |
|----------------|--------|
| Transportation | |
| Per Mile | \$0.65 |

Patching

| | |
|---------------------|---------|
| Without base course | |
| Per sq. yd. | \$16.58 |
| Per sq. ft. | \$2.00 |

COUNTY OF MAUI
REVENUES - FEES, RATES, ASSESSMENTS AND TAXES

| ACCOUNT | REVENUE SOURCE | FEE, RATE, ASSESSMENT OR TAX | HRS | COUNTY CODE | ORDINANCE |
|---------|----------------|------------------------------|-----|-------------|-----------|
|---------|----------------|------------------------------|-----|-------------|-----------|

**DEPARTMENT OF WATER SUPPLY
WATER FUND (Cont.)**

| | |
|------------------|----------|
| With base course | |
| Per sq. yd. | \$24.98 |
| Per sq. ft. | \$3.41 |
| Hot Mix | |
| Per ton | \$133.30 |
| Cold Mix | |
| Per ton | \$138.00 |
| S4C | |
| Per ton | \$45.00 |
| Crushed Rock | |
| Half ton | \$35.00 |
| Meals | |
| Breakfast | \$6.00 |
| Lunch | \$8.00 |
| Dinner | \$10.00 |

Equipment will be charged at per hour rate schedule.

| Equipment ID No. | Per Hour |
|---|----------|
| Air Compressors (Add charge for either compactor, drilling machine, or breaker) | |
| 6 160 CFM, diesel powered | \$20.00 |
| 8 125 CFM, diesel powered | \$22.00 |
| 9 185 CFM, diesel powered | \$24.00 |
| Chain Saws: | |
| 14" Target All-Purpose | \$20.00 |
| 18" | \$12.00 |
| Compactors: | |
| 12", 22", and 24" shoe | \$15.00 |
| Boom Truck: | |
| International Boom Truck | \$76.00 |
| 2001 Ford 350 w/crane | \$62.00 |
| Digger: | |
| Post Hole Digger C71-5, 8" auger | \$15.00 |
| Mini Excavator, Model 303.5 | \$36.00 |
| Mini Excavator, Model 35D | \$36.00 |
| Drilling Machine: | |
| Mueller CL-12 w/601 air motor | \$72.00 |
| Forklift: | |
| Wiggins W66ST, 1976, 6,000 lbs, 14 ft. lift | \$29.00 |
| Generator: | |
| 6KW Yamaha | \$36.00 |
| Pavement Breakers: | |
| 69 lbs. and 95 lbs. w/50-foot air hose | \$11.00 |
| Pavement Saw: | |
| Rebuild Saw | \$11.00 |
| Roller: | |
| Hamm Tandem Drum Roller | \$62.00 |

COUNTY OF MAUI
REVENUES - FEES, RATES, ASSESSMENTS AND TAXES

| ACCOUNT | REVENUE SOURCE | FEE, RATE, ASSESSMENT OR TAX | HRS | COUNTY CODE | ORDINANCE |
|---------|----------------|------------------------------|-----|-------------|-----------|
|---------|----------------|------------------------------|-----|-------------|-----------|

**DEPARTMENT OF WATER SUPPLY
WATER FUND (Cont.)**

| | |
|--|----------|
| Track or Rubber Tire Loaders: | |
| 12 Case 580K, 1990, Backhoe-Loader, diesel driven, rubber tire, CAT 416, 426 | \$90.00 |
| 31 Case 580M, 2002, Backhoe-Loader, diesel driven, rubber tire w/extendahoe | \$90.00 |
| 28, 29 John Deere 410D, 1993, Backhoe, diesel driven (Tractor) | \$90.00 |
| 44 John Deere 410E, 1995, Backhoe, diesel driven (Tractor) | \$90.00 |
| Case 580M, Backhoe-Loader | \$90.00 |
| Model 262, Bobcat | \$60.00 |
| Trucks (Includes charge for trailer, add charge for forklift): | |
| 1011 International, 1991 Dump Truck | \$96.00 |
| 1704 International, 1998 Dump Truck | \$96.00 |
| 1899/2001 Peterbilt, 2005 Model 378 Dump Truck | \$96.00 |
| 2145 Peterbilt, 2007 Model 378 Dump Truck | \$96.00 |
| 2296 2,000 Gal. Water Truck | \$108.00 |
| 1373 International, 1990 Dump Truck | \$96.00 |
| Water Pump: | |
| Trash Pump, 3" Wacker | \$36.00 |
| Welder: | |
| Miller Bobcat 250, Gas-Driven | \$30.00 |
| Materials will be charged from Stores Inventory Price list plus 20% warehouse expense. | |

COUNTY OF MAUI
REVENUES - FEES, RATES, ASSESSMENTS AND TAXES

| ACCOUNT | REVENUE SOURCE | FEE, RATE, ASSESSMENT OR TAX | HRS | COUNTY CODE | ORDINANCE |
|---------|----------------|------------------------------|-----|-------------|-----------|
|---------|----------------|------------------------------|-----|-------------|-----------|

DEPARTMENT OF WATER SUPPLY
WATER FUND (Cont.)

| | MATERIALS UNIT COST | | | | | | | | | | |
|----------------------------|---------------------|-------|-------|-------|--------|--------|--------|--------|--------|--------|--------|
| | 1/4" | 1/2" | 3/4" | 1" | 1-1/4" | 1-1/2" | 2" | 2-1/2" | 3" | 4" | 6" |
| GATE VALVE | --- | --- | 43.73 | 41.00 | 22.32 | 64.37 | 132.68 | 144.61 | 183.42 | 93.60 | --- |
| GATE VALVE, MJFE 6" | --- | --- | --- | --- | --- | --- | --- | --- | --- | --- | 668.63 |
| CHECK VALVE | --- | --- | 57.84 | 52.79 | 10.55 | 42.85 | 167.86 | 96.82 | 189.06 | --- | --- |
| BALL VALVE | --- | 22.21 | 44.88 | 72.56 | --- | 146.88 | 216.52 | 186.29 | --- | --- | --- |
| MALE ADAPTER | --- | 1.25 | 2.62 | 5.45 | 8.81 | 9.26 | 19.08 | 58.50 | 22.85 | 39.02 | --- |
| BRASS COCK | 3.38 | 23.32 | 39.71 | 57.61 | 88.80 | 111.80 | 184.44 | 181.62 | --- | --- | --- |
| SERVICB COUPLER PJ x PJ | --- | --- | 15.19 | 18.07 | 30.19 | 53.90 | 79.32 | 118.25 | --- | --- | --- |
| COUPLINGS: | | | | | | | | | | | |
| Standard Brass T X T | 0.65 | --- | 2.65 | 3.70 | 6.37 | 4.60 | 15.53 | 19.57 | 13.32 | --- | --- |
| Copper to Copper | 0.19 | 0.23 | 0.52 | 1.44 | 1.18 | 5.81 | 1.66 | --- | 30.48 | --- | --- |
| Galvanized | --- | --- | 0.74 | 1.21 | 1.81 | 2.59 | 4.66 | 19.92 | 10.32 | 25.28 | --- |
| Service x 6 | --- | 17.95 | 27.92 | 29.80 | 25.73 | 35.68 | --- | --- | 38.12 | --- | --- |
| Service x 12 | --- | --- | 36.04 | 26.46 | 48.10 | 74.90 | 89.86 | 95.98 | 114.25 | 144.10 | --- |
| Meter Coupling | --- | --- | --- | 14.90 | --- | --- | --- | --- | --- | --- | --- |
| Coupler, PJ, Male | --- | --- | 12.98 | 15.43 | 29.88 | 42.42 | 60.19 | --- | --- | --- | --- |
| Coupler, PJ, Female | --- | --- | 13.56 | 18.53 | 32.20 | 48.96 | 61.98 | 32.75 | --- | --- | --- |
| ELBOWS 45°: | | | | | | | | | | | |
| Copper to Copper | --- | --- | 0.52 | --- | --- | 0.76 | --- | --- | 50.89 | --- | --- |
| Galvanized | --- | --- | 0.92 | 1.03 | 1.60 | 1.27 | 1.74 | 3.97 | --- | 10.09 | --- |
| ELBOWS 90°: | | | | | | | | | | | |
| Copper to Copper | --- | 0.24 | 1.66 | 4.34 | 1.45 | 7.60 | 4.43 | 29.98 | 29.32 | --- | --- |
| Standard Brass T X T | --- | --- | 4.13 | 6.34 | 9.17 | 10.88 | 18.66 | 38.83 | 18.29 | --- | --- |
| Standard Brass ST | --- | --- | 4.57 | --- | --- | --- | --- | --- | --- | --- | --- |
| Galvanized | --- | --- | --- | 0.89 | 1.60 | 3.06 | 4.88 | 28.61 | 35.29 | 38.06 | --- |
| Galvanized Street | --- | --- | 0.76 | 1.60 | 1.14 | 3.41 | 7.32 | 21.24 | 28.22 | 56.58 | --- |
| PIPES: | | | | | | | | | | | |
| Copper Type K | --- | 3.55 | 3.38 | 4.86 | 6.11 | 9.32 | 15.53 | 25.03 | 4.93 | 8.35 | --- |
| Galvanized | --- | 0.73 | 1.25 | 1.70 | 2.35 | 3.05 | 4.09 | --- | 13.64 | 6.47 | --- |
| Drisco 5100, 100 ft. | --- | --- | --- | 0.77 | 0.88 | 1.10 | 2.68 | --- | --- | --- | --- |
| Drisco 5100, 300 ft. | --- | --- | --- | --- | --- | 1.20 | 2.09 | --- | --- | --- | --- |
| Drisco 8600, 20 ft. | --- | --- | --- | --- | --- | --- | --- | --- | --- | 5.44 | --- |
| Drisco 8600, 300 ft. | --- | --- | --- | --- | --- | --- | 2.50 | --- | --- | --- | --- |
| DI, TY 6" | --- | --- | --- | --- | --- | --- | --- | --- | --- | --- | 22.19 |
| PLUG - Brass | --- | --- | --- | 2.86 | 4.07 | --- | --- | --- | --- | --- | --- |
| PLUG - Galvanized | --- | 1.38 | 1.64 | 0.86 | 2.18 | 4.57 | 6.29 | 7.56 | 10.19 | 5.98 | --- |
| UNIONS: | | | | | | | | | | | |
| Copper to Copper | --- | --- | 12.35 | 6.96 | 17.22 | 26.44 | --- | 13.80 | --- | --- | --- |
| Copper to Female | --- | --- | 4.42 | 19.39 | 76.64 | 13.14 | 34.00 | 368.95 | --- | --- | --- |
| Copper to Male | --- | --- | 9.40 | 20.42 | 8.69 | 14.62 | 17.40 | 117.94 | --- | --- | --- |
| Standard Brass T X T | --- | --- | 7.72 | 7.49 | 12.14 | 10.42 | 28.79 | 38.46 | 83.05 | --- | --- |
| Galvanized | --- | --- | 1.62 | 2.35 | 3.79 | 3.98 | 5.32 | 15.44 | 13.67 | 62.42 | --- |

COUNTY OF MAUI
REVENUES - FEES, RATES, ASSESSMENTS AND TAXES

| ACCOUNT | REVENUE SOURCE | FEE, RATE, ASSESSMENT OR TAX | HRS | COUNTY CODE | ORDNANCE |
|---------|----------------|------------------------------|-----|-------------|----------|
|---------|----------------|------------------------------|-----|-------------|----------|

**DEPARTMENT OF WATER SUPPLY
WATER FUND (Cont.)**

MATERIALS UNIT COST

| TEES | T X T | C - C | GALV. | OTHER |
|-----------------------|-------|-------|-------|--------|
| 3/4 | 4.66 | 2.86 | 0.94 | --- |
| 3/4 x 3/4 x 1 | --- | 0.50 | --- | --- |
| 1 | 8.45 | 3.04 | 1.52 | --- |
| 1 x 1 x 3/4 | --- | 3.47 | --- | --- |
| 1 x 1 x 1-1/2 | --- | 29.24 | --- | --- |
| 1-1/4 | 12.10 | 8.17 | 2.41 | --- |
| 1-1/4 x 1 x 1 | --- | 12.44 | --- | --- |
| 1-1/4 x 1-1/4 x 1 | --- | 7.54 | --- | --- |
| 1-1/2 | 15.70 | 6.43 | 2.66 | --- |
| 1-1/2 x 1 x 1 | --- | 0.00 | --- | --- |
| 1-1/2 x 1-1/2 x 1 | --- | 15.53 | --- | --- |
| 1-1/2 x 1-1/2 x 1-1/4 | --- | --- | --- | --- |
| 2 | 27.11 | 33.96 | 4.32 | --- |
| 2 x 3/4 | --- | 8.09 | --- | --- |
| 2 x 2 x 1 | --- | 22.75 | --- | --- |
| 2 x 2 x 1-1/4 | --- | 8.20 | --- | --- |
| 2-1/2 | 34.12 | 3.23 | 25.70 | --- |
| 2-1/2 x 3/4 | --- | 23.20 | --- | --- |
| 2-1/2 x 2-1/2 x 1 | --- | 24.31 | --- | --- |
| 2-1/2 x 2-1/2 x 1-1/4 | --- | 5.57 | --- | --- |
| 2-1/2 x 2-1/2 x 1-1/2 | --- | 5.57 | --- | --- |
| 2-1/2 x 2-1/2 x 2 | --- | 5.57 | --- | --- |
| 3 | 66.23 | --- | 14.66 | --- |
| 4 | --- | --- | 75.78 | --- |
| 6" CUM | --- | --- | --- | 125.26 |

| LEAK REPAIR CLAMP | |
|-------------------|-------|
| 1/2 x 3 | 4.94 |
| 3/4 x 3 | 10.58 |
| 3/4 x 6 | 15.29 |
| 1 x 3 | 10.62 |
| 1 x 6 | 17.78 |
| 1-1/4 x 3 | 10.30 |
| 1-1/4 x 6 | 17.20 |
| 1-1/2 x 3 | 10.25 |
| 1-1/2 x 6 | 21.74 |
| 2 x 3 | 11.62 |
| 2 x 6 | 22.08 |
| 2-1/2 x 3 | 9.10 |
| 2-1/2 x 6 | 19.36 |
| 3 x 6 | 25.15 |
| 4 x 6 | 28.31 |

| NIPPLES | BRASS | GALV. |
|---------------|-------|-------|
| 1/2 x 4 | 3.34 | 0.40 |
| 1/2 x 6 | --- | 0.58 |
| 3/4 x Close | 1.72 | --- |
| 3/4 x 2 | 2.24 | --- |
| 3/4 x 2-1/2 | 2.71 | --- |
| 3/4 x 4 | 3.84 | 0.43 |
| 3/4 x 6 | 5.41 | 1.00 |
| 3/4 x 8 | 6.56 | --- |
| 1 x Close | 3.04 | --- |
| 1 x 2-1/2 | 3.86 | --- |
| 1 x 4 | 5.47 | 0.61 |
| 1 x 6 | 8.26 | 1.51 |
| 1-1/4 x 4 | 8.23 | 1.08 |
| 1-1/4 x 6 | 11.64 | 1.24 |
| 1-1/2 x 4 | 9.82 | 1.81 |
| 1-1/2 x 6 | 14.04 | 2.90 |
| 2 x 4 | 12.32 | 1.03 |
| 2 x 6 | 17.87 | 4.62 |
| 2-1/2 x Close | 15.26 | --- |
| 2-1/2 x 4 | 28.13 | 4.94 |

COUNTY OF MAUI
REVENUES - FEES, RATES, ASSESSMENTS AND TAXES

| ACCOUNT | REVENUE SOURCE | FEE, RATE, ASSESSMENT OR TAX | HRS | COUNTY CODE | ORDNANCE |
|---------|----------------|------------------------------|-----|-------------|----------|
|---------|----------------|------------------------------|-----|-------------|----------|

**DEPARTMENT OF WATER SUPPLY
WATER FUND (Cont.)**

MATERIALS UNIT COST

| SERVICE SADDLES | | |
|-----------------|------------|--------|
| 1-1/2 x 3/4 | Galvanized | 90.62 |
| 2 x 3/4 | Galvanized | 15.31 |
| 2 x 1 | Galvanized | 13.72 |
| 2-1/2 x 3/4 | Galvanized | 23.02 |
| 2-1/2 x 1 | Galvanized | --- |
| 3 x 3/4 | Galvanized | 106.25 |
| 4 x 3/4 | Galvanized | 23.56 |
| 4 x 1 | Galvanized | 66.07 |
| 4 x 1-1/2 | Galvanized | 42.96 |
| 6 x 3/4 | Galvanized | 52.12 |
| 3 x 1 | AC | 26.29 |
| 4 x 3/4 | AC | 84.83 |
| 4 x 1 | AC | 80.26 |
| 4 x 1-1/4 | AC | 42.46 |
| 4 x 1-1/2 | AC | 47.12 |
| 6 x 3/4 | AC | 93.66 |
| 6 x 1 | AC | 94.21 |
| 6 x 1-1/4 | AC | 69.66 |
| 6 x 1-1/2 | AC | 107.57 |
| 6 x 2 | AC | 120.71 |
| 8 x 1 | AC | 113.77 |
| 8 x 3/4 | AC | 90.46 |
| 8 x 1-1/4 | AC | 52.70 |
| 8 x 1-1/2 | AC | 123.60 |
| 8 x 2 | AC | 134.11 |
| 10 x 2 | AC | 142.92 |
| 12 x 3/4 | AC | 80.10 |
| 12 x 1 | AC | 168.34 |
| 12 x 1-1/4 | AC | 155.45 |
| 12 x 1-1/2 | AC | 205.16 |
| 12 x 2 | AC | 197.15 |

| REDUCERS | C-C | BRASS | GALV. |
|---------------|------|-------|-------|
| 3/4 x 1/2 | --- | 3.20 | 0.78 |
| 1 x 3/4 | --- | 6.25 | 1.60 |
| 1-1/4 x 3/4 | --- | --- | 0.67 |
| 1-1/4 x 1 | 2.24 | 10.56 | 0.86 |
| 1-1/2 x 3/4 | --- | 11.80 | 0.91 |
| 1-1/2 x 1 | 1.48 | 10.85 | 0.92 |
| 1-1/2 x 1-1/4 | 7.04 | 10.75 | 1.64 |
| 2 x 3/4 | --- | 13.52 | 1.31 |
| 2 x 1 | 5.82 | 15.08 | 1.32 |
| 2 x 1-1/4 | 2.09 | 14.80 | 1.31 |
| 2 x 1-1/2 | --- | 17.05 | 2.35 |
| 2-1/2 x 1 | --- | 4.08 | --- |
| 2-1/2 x 1-1/4 | 4.19 | --- | 2.57 |
| 2-1/2 x 1-1/2 | 4.66 | 21.98 | 6.10 |
| 2-1/2 x 2 | 4.82 | 26.12 | 13.81 |
| 3 x 1-1/2 | --- | --- | 3.64 |
| 3 x 2 | --- | --- | 7.72 |
| 3 x 2-1/2 | --- | 31.38 | 3.64 |
| 4 x 2 | --- | --- | 17.81 |
| 4 x 2-1/2 | --- | --- | 25.60 |
| 4 x 3 | --- | --- | 34.62 |

| NIPPLES (Cont.) | BRASS | GALV. |
|-----------------|-------|-------|
| 2-1/2 x 6 | 36.60 | 8.48 |
| 3 x 4 | --- | 4.68 |
| 3 x 6 | 53.16 | 4.57 |
| 4 x 6 | 76.49 | 11.62 |

| FULL CIRCLE CLAMP | |
|-------------------|--------|
| 4 x 8 | 88.33 |
| 4 x 12 | 152.06 |
| 4 x 15 | 175.63 |
| 6 x 12 | 164.42 |
| 8 x 8 | 66.68 |
| 8 x 12 | 182.62 |
| 12 x 16 | 307.09 |

| STAINLESS STEEL INSERTS | |
|-------------------------|------|
| 1 5100 | 2.15 |
| 1-1/4 5100 | 3.07 |
| 1-1/2 5100 | 2.74 |
| 2 5100 | 2.22 |

| MISCELLANEOUS ITEMS | |
|--------------------------------------|--------|
| THREAD BOLTS, 5/8 x 3 | 2.39 |
| THREADED RODS (PER FOOT) 3/8 | 1.57 |
| THREADED RODS (PER FOOT) 3/4 | 8.52 |
| HEX NUT, 3/4" | 0.43 |
| HEX NUT, 3/8" | 0.83 |
| HEX NUT, 5/8", OILED | 0.40 |
| MACHINE BOLT, 3/4 x 2-1/2 | 1.18 |
| MACHINE BOLT, 5/8 x 2-1/2 | 9.54 |
| MEGA LUG 6" | 31.04 |
| FLANGE GASKET #125 4" | 6.43 |
| FLANGE GASKET #125 6" | 7.16 |
| GASKET, MJ 6" | 4.00 |
| SLEEBE, SOLID CIMJ 6 X 12 | 69.68 |
| BOX, VALVE-ROUND GFREEN PLASTIC | 14.28 |
| GLAND KIT 6" | 40.92 |
| SHOVEL, FLAT | 13.70 |
| SEALING TAPE | 1.43 |
| CEMENT - 1 BAG | --- |
| HOSE REDUCER 2-1/2 x 1-1/2 | 25.24 |
| HOSE NIPPLE 2-1/2 | 39.06 |
| DOUBLE HOSE CONNECTION 2-1/2 | 70.78 |
| SLIDING VALVE BOX, TOP & BOTTOM, 24" | 157.01 |
| SVB COVER TYLER 5 1/4" | 18.18 |
| TAPPING SLEEVE 6 x 6 | 204.76 |
| PLASTIC METER BOX | 31.61 |
| CAST IRON METER BOX 5/8 & 3/4, SHORT | 111.90 |
| CAST IRON METER BOX 5/8 & 3/4, LONG | 289.94 |
| CAST IRON METER BOX 1, LOMO | 396.89 |
| HANDLE, BALL VALVE 3/4 TO 1 | 4.12 |

COUNTY OF MAUI
REVENUES - FEES, RATES, ASSESSMENTS AND TAXES

| ACCOUNT | REVENUE SOURCE | FEE, RATE, ASSESSMENT OR TAX | HRS | COUNTY CODE | ORDNANCE |
|---------|----------------|------------------------------|-----|-------------|----------|
|---------|----------------|------------------------------|-----|-------------|----------|

DEPARTMENT OF WATER SUPPLY
WATER FUND (Cont.)

MATERIALS UNIT COST

| HYDRANT RISER | |
|---------------|--------|
| 6 x 6 | 89.80 |
| 6 x 12 | 111.29 |
| 6 x 18 | 141.54 |

| HYDRANT BURY | |
|--------------|--------|
| 6 x 30 | 215.71 |
| 6 x 36 | 230.62 |
| 6 x 42 | 239.12 |
| 6 x 48 | 295.31 |

| HYDRANTS & ACCESSORIES | |
|------------------------|----------|
| #5 FIRE HYDRANT | 1,182.00 |
| #2-1/2 WHARF HYDRANT | 499.50 |
| 2-1/2" HYDRANT GASKET | 2.39 |
| 6" HYDRANT GASKET | 2.38 |
| 5/8 x 3 HYDRANT BOLTS | 4.26 |
| 5/8 x 3 MACHINE BOLTS | 1.01 |

| Corporation Stop | |
|------------------|--------|
| 1/2 | 7.94 |
| 1/2 x 3/4 | 15.10 |
| 3/4 x 3/4 | 20.50 |
| 3/4 x 1 | 18.16 |
| 1 x 1 | 5.77 |
| 1 x 1-1/4 | 29.71 |
| 1-1/4 x 1-1/2 | 77.53 |
| 1-1/2 x 2 | 78.40 |
| 2 x 2-1/2 | 123.44 |

| Ball Corporation | |
|------------------|--------|
| 1/2 | --- |
| 1/2 x 3/4 | --- |
| 3/4 x 3/4 | --- |
| 3/4 x 1 | --- |
| 1 x 1 | 45.34 |
| 1 x 1-1/4 | --- |
| 1-1/4 x 1-1/2 | --- |
| 1-1/2 x 1-1/2 | 110.95 |
| 1-1/2 x 2 | --- |
| 2 x 2 | 192.41 |
| 2 x 2-1/2 | --- |

| BUSHINGS | BRASS | GALV. |
|---------------|-------|-------|
| 1/2 x 3/8 | 1.46 | --- |
| 3/4 x 3/8 | 2.23 | --- |
| 3/4 x 1/2 | 2.29 | 0.77 |
| 1 x 3/4 | 3.31 | 0.95 |
| 1-1/4 x 3/4 | 4.61 | 0.48 |
| 1-1/4 x 1 | 5.42 | 0.42 |
| 1-1/2 x 3/4 | 9.02 | 0.92 |
| 1-1/2 x 1 | 7.82 | 1.86 |
| 1-1/2 x 1-1/4 | 7.19 | 1.43 |
| 2 x 3/4 | 9.25 | 1.98 |
| 2 x 1 | 10.69 | 2.15 |
| 2 x 1-1/4 | 9.49 | 5.90 |
| 2 x 1-1/2 | 9.62 | 1.84 |
| 2-1/2 x 3/4 | 22.10 | --- |
| 2-1/2 x 1 | 22.02 | 3.22 |
| 2-1/2 x 1-1/4 | 16.72 | 0.88 |
| 2-1/2 x 1-1/2 | 11.12 | 2.64 |
| 2-1/2 x 2 | 20.08 | 3.07 |
| 3 x 1 | --- | 3.23 |
| 3 x 1-1/4 | --- | 1.06 |
| 3 x 1-1/2 | --- | 16.09 |
| 3 x 2 | --- | 14.65 |
| 3 x 2-1/2 | 20.72 | 1.72 |
| 4 x 1-1/2 | --- | 13.15 |
| 4 x 2 | --- | 19.45 |
| 4 x 2-1/2 | 38.80 | 15.37 |
| 4 x 3 | 21.80 | 19.38 |

COUNTY OF MAUI
REVENUES -- FEES, RATES, ASSESSMENTS AND TAXES

| ACCOUNT | REVENUE SOURCE | FEE, RATE, ASSESSMENT OR TAX | HRS | COUNTY CODE | ORDINANCE |
|---------|----------------|------------------------------|-----|-------------|-----------|
|---------|----------------|------------------------------|-----|-------------|-----------|

DEPARTMENT OF WATER SUPPLY
WATER FUND (Cont.)

3482 Service Fee for Dishonored Checks \$30

3797 Water System Development Fees

| Water System Development Fund (Chapter 3.92, MCC) | | | | |
|---|-----------|--------------|---------|-------------|
| Meter Size | Source | Transmission | Storage | Fee |
| 5/8 inch | 5,789 | 3,859 | 2,412 | \$12,060 |
| 3/4 inch | 9,064 | 6,043 | 3,777 | \$18,884 |
| 1 inch | 16,011 | 10,674 | 6,671 | \$33,356 |
| 1-1/2 inch | 34,535 | 23,023 | 14,390 | \$71,948 |
| 2 inch | 60,006 | 40,004 | 25,002 | \$125,012 |
| 3 inch | 134,102 | 89,402 | 55,876 | \$279,380 |
| 4 inch | 238,301 | 158,867 | 99,292 | \$496,460 |
| 6 inch | 534,688 | 356,458 | 222,786 | \$1,113,932 |
| 8 inch | 949,165 | 632,777 | 395,486 | \$1,977,428 |
| 10 inch | 1,482,893 | 988,595 | 617,872 | \$3,089,360 |
| 12 inch | 2,134,769 | 1,423,180 | 889,487 | \$4,447,436 |

Charter 8-11.4(2)

Fixture units for single-family dwellings, single-family and accessory dwellings with 5/8", 3/4", and 1" meters shall be as follows.

| Meter Size | Included with fee | Additional unit cost | Maximum additional units |
|------------|-------------------|----------------------|--------------------------|
| 5/8 inch | 31 | \$389 | 8 |
| 3/4 inch | 53 | \$356 | 14 |
| 1 inch | 128 | \$261 | 32 |

Water system development fee rates as of April 1993 will apply to requests of applicants on the priority list for upcountry, pursuant to Section 14.13.090, MCC, as of October 31, 2001 up to a maximum of three lots.

| | | | |
|------------------------------------|--|------------|------|
| Board of Water Supply Appeals Fees | Appeals.....\$300 Filing Fee | 14.11.030 | 3557 |
| | Fee for filing appeal may be refunded if board renders final decision and order authorizing refund in full or in part of filing fee. | | |
| Late Fees | Service charge to all late payments over 30 days 1% per month | 16-7-4(b) | |
| Tenant Deposit | A tenant (including a lessee or licensee) may be required to provide a lump sum deposit equal to a two billing period estimate, as collateral for future billings. | 14.10.010 | |
| Water Shortage Penalty | Violation of "Water Conservation and Control of Water Usage During Water Shortage".....\$500 per violation | 14.06A.090 | 4178 |
| | Reinstallation fee for water meter removed.....\$100 | 14.06A.090 | 4178 |

Water Charges

Water Use Charges for Fiscal Year 2017

All figures are in dollars per 1,000 gallons. The Fiscal Year runs from July 1 to June 30. For example, Fiscal Year 2017 is from July 1, 2016 to June 30, 2017.

Rates for Single-Family Dwellings with 5/8" Meters

| Gallons | Total |
|-----------------|--------|
| 0 - 5,000 | \$2.00 |
| 5,001 - 15,000 | \$3.80 |
| 15,001 - 35,000 | \$5.70 |
| Over 35,000 | \$8.35 |

Water Shortage Rates for Single-Family Dwellings with 5/8" Meters

| Gallons | Stage 1 | Stage 2 | Stage 3 |
|-----------------|---------|---------|---------|
| 0 - 5,000 | \$2.00 | \$2.00 | \$2.00 |
| 5,001 - 15,000 | \$3.80 | \$3.80 | \$3.80 |
| 15,001 - 35,000 | \$5.70 | \$7.10 | \$8.50 |
| Over 35,000 | \$8.35 | \$9.50 | \$11.10 |

General Rates for All Other Water Consumers

| Gallons | Total |
|----------------|--------|
| 0 - 5,000 | \$2.00 |
| 5,001 - 15,000 | \$3.80 |
| Over 15,000 | \$5.70 |

Water Shortage Rates for All Other General Water Consumers

| Gallons | Stage 1 | Stage 2 | Stage 3 |
|----------------|---------|---------|---------|
| 0 - 5,000 | \$2.00 | \$2.00 | \$2.00 |
| 5,001 - 15,000 | \$3.80 | \$3.80 | \$3.80 |
| Over 15,000 | \$5.70 | \$7.10 | \$8.50 |

Agricultural Rates

| Gallons | Total |
|-------------|--------|
| Over 15,000 | \$1.10 |

Non-Potable Agricultural Rates

| Gallons | Total |
|-----------|--------|
| All usage | \$1.00 |

Water Service Charges

Below are regular and agricultural water service charges.

| Size of Meter | Cost Per Meter Per Month |
|---------------|--------------------------|
| 5/8 inch | \$19.25 |
| 3/4 inch | \$31.00 |
| 1 inch | \$46.00 |
| 1 1/2 inch | \$88.00 |
| 2 inch | \$137.00 |
| 3 inch | \$242.00 |
| 4 inch | \$420.00 |
| 6 inch | \$770.00 |
| 8 inch | \$1,215.00 |

- Information on sewer rates is available at the Department of Environmental Management
- Rates and Fees Charged to Customers and Contractors (water fund only)

PART 4
FIXING RATES FOR THE FURNISHING OF WATER SERVICE IN THE
COUNTY OF KAUAI

SECTION I - GENERAL USE RATES

1. **Service Charge.** For each service there shall be a charge per month imposed based on the size of the meter, or its service capacity equivalence in the case of parallel meters, as follows:

| Meter Size | Effective | Effective | Effective | Effective |
|------------|-------------------|----------------|----------------|----------------|
| | January 1 2012 | July 1 2012 | July 1 2013 | July 1 2014 |
| 5/8" | \$12.00 | \$14.40 | \$16.00 | \$17.75 |
| 3/4" | 16.75 | 20.00 | 22.25 | 24.75 |
| 1" | 24.25 | 29.50 | 32.75 | 36.50 |
| 1-1/2" | 46.00 | 53.00 | 59.00 | 65.50 |
| 2" | 70.00 | 81.00 | 90.00 | 100.00 |
| 3" | 132.00 | 146.75 | 163.00 | 181.00 |
| 4" | 216.00 | 240.00 | 267.00 | 297.00 |
| 6" | 420.00 | 475.00 | 528.00 | 587.00 |
| 8" | 680.00 | 755.00 | 840.00 | 934.00 |

2. **Use Charge.** In addition thereto, there shall be a consumption charge imposed per 1,000 gallons as follows:

| Use Rate Block | Effective | Effective | Effective | Effective |
|-----------------------|-------------------|----------------|----------------|----------------|
| | January 1 2012 | July 1 2012 | July 1 2013 | July 1 2014 |
| 0 th Block | \$3.20 | \$3.40 | \$3.60 | \$3.80 |
| 1 st Block | 3.50 | 3.90 | 4.35 | 4.85 |
| 2 nd Block | 4.25 | 4.50 | 5.05 | 5.65 |
| 3 rd Block | 6.85 | 7.60 | 8.50 | 9.50 |
| 4 th Block | 7.20 | 8.05 | 8.95 | 10.00 |

The 0th, 1st, 2nd, 3rd, and 4th block consumption thresholds vary with the size of each meter, and shall be as follows in thousands of gallons per monthly billing:

| Meter Size | 0 th | 1 st | 2 nd | 3 rd | 4 th |
|---------------|--------------------------|--------------------------|--------------------------|--------------------------|-----------------------|
| | Rate Block Minimum | Rate Block From-To | Rate Block From-To | Rate Block From-To | Rate Block Over |
| 5/8" | 1 | 1-7 | 7-14 | 14-18 | 18 |
| 3/4" | 2 | 2-29 | 29-57 | 57-65 | 65 |
| 1" | 3 | 3-68 | 68-137 | 137-175 | 175 |
| 1-1/2" | 10 | 10-169 | 169-337 | 337-387 | 387 |
| 2" | 12 | 12-400 | 400-750 | 750-925 | 925 |
| 3" | 50 | 50-600 | 600-1,200 | 1,200-1,750 | 1,750 |
| 4" | 175 | 175-1,000 | 1,000-2,500 | 2,500-2,750 | 2,750 |
| 6" | 225 | 225-4,000 | 4,000-7,500 | 7,500-10,000 | 10,000 |
| 8" | 250 | 250-1,000 | 1,000-2,500 | 2,500-12,500 | 12,500 |

3. Wharfage Fee. Where applicable, the Department of Transportation's wharfage fee shall be charged in addition to the above use and service charges.

SECTION II - BULK RATES

Bulk rates for specified areas may be established by the Board providing the following conditions are met:

1. The area consists of existing dwellings or business establishment with bulk rates built prior to September 11, 1992.
2. The system has been offered to the Board but refused because of substandard or obsolete pipeline and fixtures.
3. The lots or parcels are under diversified ownership and not under a single or limited number of owners (three (3) and less).
4. There is a savings to the Board in maintenance and operating costs in contrast to accepting the system.
5. All bulk rates shall be renegotiated biennially and may continue upon concurrence of both parties.

SECTION III - AGRICULTURAL RATES

1. Service Charge. For each agricultural service there shall be a charge per month imposed based on the size of the meter, or its service capacity equivalence in the case of parallel meters, as follows:

| <u>Meter Size</u> | <u>Effective</u> | <u>Effective</u> | <u>Effective</u> | <u>Effective</u> |
|-------------------|------------------|------------------|------------------|------------------|
| | <u>January 1</u> | <u>July 1</u> | <u>July 1</u> | <u>July 1</u> |
| | <u>2012</u> | <u>2012</u> | <u>2013</u> | <u>2014</u> |
| 5/8" | \$15.00 | \$15.00 | \$16.00 | \$17.75 |
| 3/4" | 20.00 | 20.00 | 22.25 | 24.75 |
| 1" | 30.00 | 30.00 | 32.75 | 36.50 |
| 1-1/2" | 55.00 | 55.00 | 59.00 | 65.50 |
| 2" | 90.00 | 90.00 | 90.00 | 100.00 |
| 3" | 160.00 | 160.00 | 163.00 | 181.00 |
| 4" | 260.00 | 260.00 | 267.00 | 297.00 |
| 6" | 500.00 | 500.00 | 528.00 | 587.00 |
| 8" | 800.00 | 800.00 | 840.00 | 934.00 |

2. In addition to the agricultural service charge described in this Section III, for all water drawn, where such water is used for agriculture, stock raising, or dairy farming on a commercial basis, the following consumption charge shall be imposed for each 1,000 gallons used, as of the following effective dates:

| <u>Use</u> | <u>Effective</u> | <u>Effective</u> | <u>Effective</u> | <u>Effective</u> |
|-----------------------|------------------|------------------|------------------|------------------|
| | <u>January 1</u> | <u>July 1</u> | <u>July 1</u> | <u>July 1</u> |
| <u>Rate</u> | <u>2012</u> | <u>2012</u> | <u>2013</u> | <u>2014</u> |
| 1 st Block | \$1.75 | \$1.90 | \$2.05 | \$2.20 |

3. In order to qualify for the charges and rates described in this Section III, the applicant shall file annually with the Department of Water a written application, shall furnish annually satisfactory proof, including State of Hawaii General Excise Tax License for the engagement of business in agriculture, stock raising or dairy farming on a commercial basis and shall have a DOW approved reduced pressure backflow preventer installed on the customers side of the meter with a current inspection certificate. The applicant for agricultural rates must agree to accepting service from the Department of Water on an interruptible basis; i.e., the Department retains the right to limit or restrict water flow for agricultural uses in the event of water shortage or in the event water service to domestic users is curtailed due to agricultural uses. The agricultural rates shall not apply to processing activities, such as canneries, mills, markets or other establishments engaged in the conversion, treatment or packaging of agricultural products.

SECTION IV - SHIPPING RATES

1. For each ship or vessel served, there shall be both an opening charge and a closing charge imposed as follows:
 - A. Opening and Closing Charges:
 1. Charges applicable during regular Water Department working hours: \$53.00
 2. Charges applicable during Saturdays, Sundays, State of Hawai'i holidays, and hours other than regular Water Department working hours: \$123.00
2. Additionally, for all water drawn by ships and vessels, there shall be a consumption charge imposed for each 1,000 gallons of water drawn, as follows:

| | |
|----------------------------|--------|
| Effective January 1, 2009: | \$3.70 |
| Effective January 1, 2010: | \$4.00 |
3. Additionally, for all water drawn by ships and vessels, there shall be a State of Hawai'i Department of Transportation wharfage fee which is the current approved rate as per the Hawai'i Department of Transportation Approved Rate imposed for each 1,000 gallons of water drawn.

SECTION V - PRIVATE FIRE SERVICE CHARGES

1. Types of Fire Lines: There are two types of fire lines, not located on road rights of way, that are considered private fire lines:
 - A. "Fire lines with Detector Check Assemblies" - Fire lines with detector check assemblies which are not be used for anything other than firefighting without written permission from DOW.
 - B. "Fire lines with Full Flow Meters" - Fire lines with full flow meters allowed for dual use in order to provide normal consumption as well as fire flow. These dual use services are oversized, compared to normal service meters, in order to allow for higher than normal consumption. The oversized meter has two meters, a Full Flow Meter and a Small Meter, both of which do not accurately read low flow; the monthly service charge for the low flow offsets the inaccuracy of the meter.
2. Charges for Fire lines with Detector Check Assemblies

- A. **No Charge for Fire Consumption:**
Fire lines with Detector Check Assemblies, which are used for the sole purpose of firefighting, will not be charged a consumption charge in the case of an actual fire, provided that the use for firefighting purposes is verified in writing, by the County Fire Chief, stating the time and date the firefighting started and ended.
- B. **Total Charges:** Although water is not permitted to be used through Fire lines with Detector Check Assemblies for anything other than firefighting, there remains the possibility of leakage, testing, and other impermissible uses. Therefore, charges for Fire lines with Detector Check Assemblies shall equal the sum of all of the following:
 - i. Private Fire Service Inlet Line Charge, as determined in Part 4, Section V, paragraph 4 below; and
 - ii. Meter Reading Service Charge; and
 - 1. Meter Reading Service Charge is equal to the service charge correlated with the detector check assembly meter size as described and laid out in Part 4, Section I of DOW Rules and Regulations;
 - 2. The minimum use service charge imposed in Part 4, Section I of DOW Rules and Regulations shall not apply for the detector check assembly;
 - 3. Removal of the security tag shall result in a fine of \$2,000.
 - iii. Use Determination Charge.
 - 1. All consumption, including consumption for annual line testing and line leakage, will be billed for use through the: 1) Detector Check Assembly Meter; and 2) Unmetered Fire line
 - a. Unmetered Fire line:
 - i. Total unmetered fire line consumption shall be determined by taking the area ratio from the area of the detector check assembly meter cross-sectional area divided into the cross-sectional area of the inlet line, as listed in Part 4, Section V, paragraph 5 below, multiplied by the reading obtained from the detector check assembly meter.
 - b. Detector Check Assembly Meter:
 - i. The portion of the consumption obtained from the reading on the detector check assembly meter will be billed, according to Part 4, Section I, based on the detector check assembly meter reading from the first one thousand gallons use.
 - ii. The difference of the consumption found from the Use Determination minus the detector check assembly meter reading will be billed at the Block Rate in Part 4, Section I, for a meter equivalent to the size of the line serving the detector check assembly for all remaining consumption without any minimum use charge.

3. **Charges for Fire lines with Full Flow Meters**

- A. **Total Charges:** Charges for Fire lines with Full Flow Meters shall equal the sum of all of the following:
 - i. Private Fire Service Inlet Line Charge, as determined in Part 4, Section V, paragraph 4 below; and
 - ii. Full Flow Meter Charge; and
 - 1. Full Flow Meter Charge shall equal the service charge imposed in Part 4, Section I and shall be based on the full flow meter size.
 - 2. Any consumption, including consumption for the annual line testing, line leakage, or fire use, measured on the meter, will be billed at the general use rate for water as listed in Part 4, Section 1 of these rules.

3. Removal of the security tag shall result in a fine of \$2,000.00.
- iii. Small Meter Charge.
 1. The Small Meter Charge shall equal the block rate charge for the respective meter size, as laid out in Part 4, Section 1 of these rules.

4. Private Fire Service Inlet Line Charge: For the two types of private fire service connection allowed for the purpose of automatic fire sprinklers or other private fire protection, there shall be a Private Fire Service Inlet Charge, per month, based on the diameter of the inlet line connection as follows:

PRIVATE FIRE SERVICE INLET CHARGE

| <u>Inlet Line Diameter</u> | <u>Effective January 1 2012</u> | <u>Effective July 1 2012</u> | <u>Effective July 1 2013</u> | <u>Effective July 1 2014</u> |
|----------------------------|---------------------------------|------------------------------|------------------------------|------------------------------|
| 2" | \$20.50 | \$22.75 | \$25.25 | \$28.25 |
| 3" | 35.50 | 39.50 | 44.00 | 49.00 |
| 4" | 58.00 | 64.50 | 71.75 | 80.00 |
| 6" | 121.00 | 134.50 | 149.50 | 166.00 |
| 8" | 206.00 | 229.00 | 255.00 | 283.00 |

5. Area Ratio Table

| <u>Line Diameter</u> | <u>5/8 meter to line size dia ratio</u> | <u>3/4 meter to line size dia ratio</u> | <u>1" meter to line size dia ratio</u> | <u>1 1/2" meter to line size dia ratio</u> | <u>2" meter to line size dia ratio</u> | <u>3" meter to line size dia ratio</u> | <u>4" meter to line size dia ratio</u> |
|----------------------|---|---|--|--|--|--|--|
| <u>2.000</u> | <u>10.24</u> | <u>7.1</u> | <u>4.0</u> | <u>1.8</u> | | | |
| <u>3.000</u> | <u>23.04</u> | <u>16.0</u> | <u>9.0</u> | <u>4.0</u> | <u>2.3</u> | | |
| <u>4.000</u> | <u>40.96</u> | <u>28.4</u> | <u>16.0</u> | <u>7.1</u> | <u>4.0</u> | <u>1.8</u> | |
| <u>6.000</u> | <u>92.16</u> | <u>64.0</u> | <u>36.0</u> | <u>16.0</u> | <u>9.0</u> | <u>4.0</u> | <u>2.25</u> |
| <u>8.000</u> | <u>163.84</u> | <u>113.8</u> | <u>64.0</u> | <u>28.4</u> | <u>16.0</u> | <u>7.1</u> | <u>4</u> |

SECTION VI - PUBLIC FIRE SERVICE CHARGES

For each fire hydrant or standpipe connected to operating pipelines of the Department of Water, there shall be a charge imposed against the County of Kauai as follows:

| <u>Type and Size</u> | <u>Effective January 1 2012</u> | <u>Effective July 1 2012</u> | <u>Effective July 1 2013</u> | <u>Effective July 1 2014</u> |
|----------------------|---------------------------------|------------------------------|------------------------------|------------------------------|
| 2-1/2" Standpipe | \$7.75 | \$8.75 | \$9.75 | \$10.75 |
| 4" Hydrant | 16.50 | 18.50 | 20.50 | 23.00 |
| 6" Hydrant | 48.50 | 54.00 | 60.00 | 67.00 |

SECTION VII - OTHER CHARGES

1. **Restoration of Water Service.** If a consumer's water service is turned off for failure to pay a bill, for violation of any of the provisions of these rules and regulations, or for other reasons, all outstanding accounts against said consumer plus the charge for reopening, reinstallation or reconnection must be paid before water service be restored. Said charges shall be as established by the Department.
2. **Fire Hydrant and Other Temporary Meters.** In addition to regular meter service charge and water consumption charge, there shall be installation, removal, testing and user charges for all Fire Hydrant and other temporary meters as established by the Department.
3. **Pass Through of Private Charges.**

a) As used in this Paragraph 3:

"Private charge" or "private charges" means charges, fees, assessments, exactions, and all other moneys a private water company may require the Department to pay to permit the Department to purchase water from the company. The terms include contribution-in-aid-of-construction charges that a company may assess against the Department.

"Private water company" or "company" means any department or agency of the federal government or the State of Hawaii, any private person, trust, association, corporation, partnership, or business, and any water utility regulated by the Hawaii Public Utilities Commission.

(b) Whenever the Department purchases water from a private water company for end use by any of the Department's consumers or prospective consumers and the company imposes private charges in excess of any similar charge or fee imposed under the Department's administrative rules, the Department shall require a consumer or prospective consumer to pay, in addition to the Department's charge or fee, the difference between the charge or fee imposed under the Department's rules and the similar private charge imposed by the company. If the private charge imposed is less than the similar charge or fee imposed under the Department's administrative rules, the consumer or prospective consumer shall not be entitled to the difference between the private charge imposed and the similar charge or fee imposed under the Department's rules.

Whenever the Department purchases water from a private water company for end use by any of the Department's consumers or prospective consumers and the company imposes private charges that are dissimilar to any charge or fee imposed under the Department's administrative rules, the Department shall require a consumer or prospective consumer to pay an amount equal to the dissimilar private charge imposed by the company."

SECTION VIII - TEMPORARY GRANTS OF WATER

1. **Purpose.** The purpose of this section is to establish standards for temporary grants of water to support the initial development of county or state public beautification projects or the initial or further development of county or state public parks and public ways.
2. **Temporary Grants of Water.** The Board of Water Supply may, in its discretion, authorize temporary grants of water to support the initial development of county or state public beautification projects or the initial or further development of county or state public parks and public ways.

Any county or state department, office, or agency wishing to receive such temporary grants of water shall apply to the Board of Water Supply for such temporary grants. The application shall explain or describe in detail the contemplated project, why a temporary grant of water from the Department is

necessary, what other efforts the applicant has made to obtain water from other sources, for what specific purposes the water will be used, and how the water provided will yield public benefits. The applicant shall also certify that there were no other available sources which can be used to support the project in question.

For each application, the Board shall determine and establish a maximum time limit that water may be provided to an applicant and a quantity limit on the amount of water that may be drawn.

The Board and the Manager and Chief Engineer may prescribe conditions under which water may be drawn so that the provision of water to the applicant does not adversely affect the Department's ability to provide water to its other users.

SECTION IX - COST OF POWER ADJUSTMENT CLAUSE

All water consumption (for general use, agriculture use and ships) shall be subject to the imposition of a Cost of Power Adjustment as part of all water consumption charges.

The Department will review the actual unit costs of power for each twelve month period ending March 31st as part of the Department's annual budget review process. The power cost adjustment for the upcoming fiscal year will be calculated as the sum of the following two components:

- 1) the difference (plus or minus) between budgeted unit power costs for the upcoming fiscal year and the projected unit power costs, and
- 2) the difference (plus or minus) between the actual unit power costs incurred during the twelve-month period ending March 31st as previously described and the projected unit power costs.

The sum of these two components, calculated on a dollar[s] per thousand gallons basis, will be applied to all water consumption.

Any power cost adjustments will be implemented on July 1st of each year.

SECTION X – LATE CHARGES

A late payment charge may be applied to any delinquent balance payable to the Department. The late payment charge shall be assessed at the rate of half a percent (0.5%) for each month or fraction thereof against the delinquent balance, beginning 30 days after the date of the bill.

For the purposes of this section, 'delinquent balance' includes any loan, fee, charge, or other liquidated sum which is 30 days past due to the Department, regardless of whether there is an outstanding judgment for that sum, and whether the sum has accrued through contract, subrogation, tort, operation of law, or administrative order.

PART 5
FACILITIES RESERVE CHARGE
within the County of Kauai
and Providing Penalties for the Violations Thereof

SECTION I – GENERAL PROVISIONS

1. Purpose and Authority
 - a. Capital water facilities expansion is needed in order to accommodate increased demands on existing source, storage, and transmission pipeline capacity due to new development and/or additional demand of existing users. **New development and/or additional demand shall be assessed a Facilities Reserve Charge** in proportion to its impact and demand on capital water facilities. The Facilities Reserve Charge shall be expended for public capital water facilities projects. These rules were enacted pursuant to Hawaii Revised Statutes (H.R.S.) §46-141 *et seq.* and other applicable State law.

2. Findings
 - a. In the review of the impact of growth relative to the existing and planned capital water system facilities capacity available to the water system, the Board hereby finds that the recent and anticipated population growth rates and corresponding water demands would place additional burdens on the existing water system. The Board further finds that such growth and increased demand would necessitate increased expenditures of public funds in order to create adequate facilities and to promote and protect the public health, safety, and welfare. The Board also finds that it is fair and reasonable to impose additional fees to accommodate such development. *Finally, the Board finds that establishing benefit zones as identified in Hawaii Revised Statutes (H.R.S.) §46-14* is not necessary as a reasonable benefit can otherwise be derived.*

 - b. The following rules shall govern the assessment of impact fees for the Board of Water Supply, County of Kauai capital water facilities expansion. New development and/or additional demand shall be assessed impact fees in proportion to its demand on capital water facilities and the impact fees assess shall be expended for public capital water facilities projects. The Facilities Reserve Charge (FRC) was adopted in accordance with the report prepared by an independent consultant retained by the County of Kauai, Board of Water Supply (Board) to

assess and study water facilities. The report calculated the proportionate costs associated with the water development needs as laid out in the Board approved Department facilities needs assessment study entitled "Water Plan 2020", as amended.

SECTION II – DEFINITIONS

"Affordable or Workforce Housing Project" shall mean any project confirmed or sponsored by the County Housing Agency as a residential development where the majority of housing lots, single family dwelling units, or multiple-family dwelling units are affordable housing or workforce housing as defined in Chapter 7A of the Kauai County Code 1987, as amended.

"Applicant" means any person, individual, subdivider, corporation, partnership, business, organization, association, or other entity whatsoever that applies for water service from the Department.

"Consumer" has the meaning ascribed to it under Section I of Part 2 of the Department's Rules and Regulations.

"Facilities Reserve Charge" (FRC) means the fee to be paid by an Applicant as their proportionate share in required improvements to capital water facilities.

"Grant Funds" shall mean a contribution, gift, or subsidy bestowed to the Board for specific water facilities improvement associated with a specific project that necessitates such water facilities improvements.

"Grantor" means the person or entity that makes a grant of funds.

"Offset" means a reduction in Facilities Reserve Charge designed to fairly reflect the value of non-site related capital water facilities improvements provided by an Applicant pursuant to Department of Water requirements.

"Recoupment" shall be defined as in H.R.S. 46-141, as amended, and refers to the proportionate share of the water facility capital improvement costs of excess capacity in existing water capital facilities where excess capacity has been provided in anticipation of the needs of development.

"Subdivider" has the meaning ascribed to it under section I of Part 3 of the Department's Rules and Regulations.

“Subdivision” has the meaning ascribed to it under section I of Part 3 of the Department’s Rules and Regulations.

“Water transmission main” or “main” means a main extension under Paragraph 2.d [2.a.(4)] of Section II of Part 2 of the Department’s Rules and Regulations. As used in this Section, the following rules of construction shall apply:

Number. Words in the singular or plural number signify both the singular and plural number.

“Or”, “and”. Each of the terms “or” and “and”, has the meaning of the other or of both.

SECTION III – APPLICABILITY

1. The Facilities Reserve Charge shall be assessed against all new developments and subdivisions requiring supply of water from the County of Kauai, Department of Water, and existing developments requiring new or additional supply of water from the Department’s system. The Facilities Reserve Charge must be paid before water services are made available to the new or existing development.
2. The Facilities Reserve Charge shall be paid by all Applicants for new or additional water service, including but not limited to the following:
 - a. All irrigation services and/or meters.
 - b. Additional buildings to be connected to existing services where additional demands are indicated. The charges shall be based on the meter sizes required if the buildings were metered separately.
 - c. Additional dwellings connected to existing services and meters under the categories of single family and multi-family residential units. The charges will be based on the established schedule of charges for the respective categories.
 - d. Changes in service that require an increase in meter size.
 - e. Where an FRC was paid but a water meter was never installed to serve the subject property, the applicant shall pay the Facilities Reserve Charge in accordance with Part 5, Section IV (4) of these Rules.

3. The Facilities Reserve Charge shall apply to all Applicants for water service as follows:
 - a. For each parcel created by subdivision, including the first lot created; and for every new single family residential dwelling unit not yet metered and a Facilities Reserve Charge has not yet been paid, the applicable Facilities Reserve Charge shall be \$14,115.00.
 - b. The Facilities Reserve Charge for multi-family and/or resort development will be the cost of the approved meter size or the cost of \$9,880.00 per unit or hotel room, whichever number is larger.
 - c. For all other uses, the Facilities Reserve Charge shall be determined by the size of the meter, as shown below. Meter sizes shall be determined by the Department and not by the Developer or Applicant.

| Meter Size | Amount |
|------------|-----------------|
| 5/8" | \$ 14,115.00 |
| 3/4" | \$ 21,170.00 |
| 1" | \$ 35,290.00 |
| 1 1/2" | \$ 70,580.00 |
| 2" | \$ 112,920.00 |
| 3" | \$ 225,840.00 |
| 4" | \$ 352,880.00 |
| 6" | \$ 705,750.00 |
| 8" | \$ 1,129,200.00 |

Facilities Reserve Charges are periodically adjusted by the Department. These adjustments may increase or decrease existing Facilities Reserve Charge amounts. Where adjustments to Facilities Reserve Charges result in decreases of such charges, no refund will be made of the difference between the higher, pre-existing charges and the lower, adjusted charges.

SECTION IV – COLLECTION AND REFUND OF FRC

1. Upon collection of the Facilities Reserve Charge, the Facilities Reserve Charge shall be deposited in a special trust fund or interest-bearing account. The portion that constitutes recoupment may be transferred to any appropriate fund.

2. If the Facilities Reserve Charge is not expended or encumbered within six years from the date of collection, it shall be refunded to the property owner or the property owner's successor in title, together with accrued interest (if any).
 - a. An application for a refund shall be submitted to the Board within one year of the date upon which the refund right arises;
 - b. Amounts unclaimed within one year of the date the right to refund arises shall be retained in a special trust fund or interest bearing account and shall be expended for capital facilities improvement projects.
3. If the Board terminates the Facilities Reserve Charge (or analogous) requirement, all unexpended or unencumbered funds shall be refunded to the property owner or the property owner's successor in title, together with accrued interest (if any).
 - a. Public notices of termination and availability of refunds shall be given by the Board at least two times in a manner approved by the Board. All funds available for refund shall be retained for a period of one year and at the end of said one year period, any remaining funds may be transferred to the Board's general fund and expended for any public purposes involving water supply or service as determined by the Board.
4. No FRC refund shall be made for existing meters requiring a decrease in water demand, decrease in meter size, or decrease in existing water supply fixture units; or requests to change service categories.
5. Recoupment shall be exempt from subsections (2) and (3).
6. Facilities Reserve Charge Paid Prior to Enactment of Part 5 Rules
 - a. This Section applies to those Applicants that have paid a Facilities Reserve Charge prior to enactment of these Part 5 Rules and have failed to install a water meter on the subject property for which the Facilities Reserve Charge was paid, hereinafter referred to as "Prior Applicants".
 - b. Prior Applicants shall have three (3) years from the date of enactment of these Part 5 Rules, hereinafter referred to as the "Grace Period", to install a water meter, at no additional Facilities Reserve Charge cost.

- c. After expiration of the Grace Period, Prior Applicants must pay the difference of the original Facilities Reserve Charge paid and the Facilities Reserve Charge in effect at the time the meter is installed.
 - d. The Manager may grant exceptions to item 6c if the Manager finds all of the following:
 - i. Strict application of the rule would cause an absurd, unfair, or unreasonably harsh result; and
 - ii. The Prior Applicant's circumstance or condition is unique or exceptional and the Manager would grant the same request if made by ever similarly situated Prior Applicant; and
 - iii. Such exception thereof is as reasonably necessary or expedient and not contrary to law or the intent and purposes of these rules.
7. Facilities Reserve Charge Paid After Enactment of Part 5 Rules
- a. The Department may issue conditional approval for water service requests.
 - b. A conditional approval shall be valid for a period of one year and shall expire unless installation of the meter occurs within that period or an extension of the conditional approval is granted.
 - i. An extension of the conditional approval may be granted for a single additional one-year period.
 - c. Upon expiration, the conditional approval shall become null and void and the Applicant will be required to re-apply to the Department of Water for water service. Any request for water service will be dependent on the adequacy of the source, storage, and transmission facilities existing at that time.
 - d. A Water Meter Application and FRC payment can only be made upon completing the requirements set forth in the conditional approval.
8. Facilities Reserve Charges for Affordable and Work Force Facilities Housing Projects

- a. The Manager may defer collection of Facility Reserve Charges for Affordable or Workforce Housing Projects, provided, however that applicable Reserve Charges shall be collected before building permit approval or installation of applicable meters, whichever occurs first.
- b. Administrative fees related to the Facility Reserve Charge shall be waived for Affordable or Workforce Housing Projects.

SECTION V - FRC OFFSETS

When an Applicant, is required to construct and dedicate water source or water storage facilities, or water transmission mains, to the Department, the following rules shall apply:

1. The applicable FRC liability of such Applicant, shall be offset by up to 22% where water source improvements are constructed, up to 41% where water storage improvements are constructed, and up to 37% where water transmission mains are constructed; provided that the total amount of all offsets that an Applicant, receives shall not exceed 100% of the Applicant's, FRC liability.
 - a. An Applicant who provides 100% of the necessary source or storage or transmission requirements shall be entitled to an offset for the entire amount per category of source, storage, or transmission improvements as shown above.
2. The Department, and not the Applicant, shall calculate and determine the total amount of an Applicant's, FRC offset in any given case. The Department may require the Applicant to submit documentation verifying the actual cost of a source or storage improvement or transmission main.
3. The offsets described in this Section V "FRC Offsets" shall not apply to water transmission mains constructed by an Applicant which are within or adjacent to a subdivision or lands either 1) owned by the Applicant, or 2) developed by the Applicant. Where water transmission mains are constructed within, adjacent to, or outside of such subdivisions or lands, the offsets shall apply only to mains constructed outside of and off-site from such subdivisions or lands.
4. Grant Funds. Grant funds, specifically allocated to projects by the Grantor, may be used by the Manager to offset the FRC assessed to said projects on a dollar for dollar basis as it relates to source development, storage development and/or transmission main development.

- a. Applicants shall be offset by up to 22% where water source improvements are constructed; up to 41% where water storage improvements are constructed; and up to 37% where water transmission mains are constructed; provided that the total amount of all offsets that an Applicant receives shall not exceed 100% of the Applicant's FRC liability.
- b. The Manager shall determine which improvements are eligible for FRC offsets.
- c. FRC offsets shall be afforded only to those Applicants that are beneficiaries of the Grantor and identified as such at the time the Grant fund is made.
- d. FRC offsets for Grant Funds shall be a one-time event.

SECTION VI – APPEAL OF FACILITIES RESERVE CHARGE

1. Any person assessed a Facilities Reserve Charge under these rules may contest the amount of the Facilities Reserve Charge assessed by following the requirements in Part 1 of these Rules and Regulations.

Our Mission:

Providing Safe & Dependable Drinking Water at a Reasonable Cost

How is your money spent?

Water Quality

Providing safe drinking water is the foremost goal of the Department. We intend to meet the stringent requirements of the Federal Safe Drinking Water Act. This includes testing of the water on a regular basis, developing better sources, and furnishing more treatment facilities.

Dependable Systems

Making sure that you have water involves drilling more wells (since well water is more dependable and less susceptible to droughts than surface sources); repairing and replacing outdated systems; and installing new modern equipment to monitor our systems.

You Can Contact Us at the Following Numbers:

Administration/Finance/General(808) 961-8050
 Billing/Customer Service(808) 961-8060
 Engineering(808) 961-8070
 Emergencies & Field Operations(808) 961-8790
 Water Quality(808) 961-8670
 Website Addresswww.hawaiiidws.org

A. MONTHLY STANDBY CHARGES*

All meter connections shall be subject to a monthly standby charge as follows:

| Meter Size (inches) | Effective July 1, 2015 | Effective July 1, 2016 | Effective July 1, 2017 | Effective July 1, 2018 | Effective July 1, 2019 |
|---------------------|------------------------|------------------------|------------------------|------------------------|------------------------|
| 5/8" | \$ 16.75 | \$ 17.40 | \$ 18.30 | \$ 19.20 | \$ 20.20 |
| 1" | 36.00 | 37.00 | 39.00 | 41.00 | 43.00 |
| 1-1/4" | 67.00 | 70.00 | 73.00 | 77.00 | 80.00 |
| 1-1/2" | 104.00 | 108.00 | 113.00 | 119.00 | 125.00 |
| 2" | 190.00 | 197.00 | 207.00 | 218.00 | 229.00 |
| 3" | 313.00 | 325.00 | 342.00 | 359.00 | 377.00 |
| 4" | 621.00 | 646.00 | 678.00 | 712.00 | 747.00 |
| 6" | 990.00 | 1,030.00 | 1,081.00 | 1,135.00 | 1,192.00 |
| 8" | 1,426.00 | 1,480.00 | 1,560.00 | 1,630.00 | 1,720.00 |
| 10" | 2,490.00 | 2,590.00 | 2,720.00 | 2,860.00 | 3,000.00 |

*Standby charge is a minimum monthly charge.

B. GENERAL USE RATES (per 1,000 gallons)

In addition to standby, power cost, and energy CIP charges, a consumption charge will be applied to all general use customers as follows:

| | Effective July 1, 2015 | Effective July 1, 2016 | Effective July 1, 2017 | Effective July 1, 2018 | Effective July 1, 2019 |
|-----------------------|------------------------|------------------------|------------------------|------------------------|------------------------|
| 1 st Block | \$ 0.89 | \$ 0.91 | \$ 0.91 | \$ 0.91 | \$ 0.92 |
| 2 nd Block | 1.80 | 1.80 | 1.88 | 1.95 | 2.01 |
| 3 rd Block | 3.10 | 3.20 | 3.30 | 3.40 | 3.53 |
| 4 th Block | 4.06 | 4.20 | 4.35 | 4.50 | 4.69 |

BLOCK THRESHOLDS (gallons per month)

The threshold for the rate blocks vary with the size of the water meter as follows:

| Meter Size (inches) | 1 st Block | 2 nd Block | 3 rd Block | 4 th Block |
|---------------------|-----------------------|-----------------------|--------------------------|-----------------------|
| 5/8" | 5,000 | 5,001 - 15,000 | 15,001 - 40,000 | > 40,000 |
| 1" | 5,000 | 5,001 - 100,000 | 100,001 - 300,000 | > 300,000 |
| 1-1/4" | 5,000 | 5,001 - 400,000 | 400,001 - 1,000,000 | > 1,000,000 |
| 2" | 5,000 | 5,001 - 900,000 | 900,001 - 2,000,000 | > 2,000,000 |
| 3" | 5,000 | 5,001 - 2,000,000 | 2,000,001 - 5,000,000 | > 5,000,000 |
| 4" | 5,000 | 5,001 - 4,700,000 | 4,700,001 - 10,000,000 | > 10,000,000 |
| 6" | 5,000 | 5,001 - 10,000,000 | 10,000,001 - 25,000,000 | > 25,000,000 |
| 8" | 5,000 | 5,001 - 20,000,000 | 20,000,001 - 50,000,000 | > 50,000,000 |
| 10" | 5,000 | 5,001 - 40,000,000 | 40,000,001 - 100,000,000 | > 100,000,000 |
| 12" | 5,000 | 5,001 - 60,000,000 | 60,000,001 - 150,000,000 | > 150,000,000 |

EXPLANATION OF CHARGES:

- Your water bill consists of three components:
- Standby Charge:** This is a minimum monthly service charge based on meter size.
 - Consumption Charge:** This is a service charge based on water use.
 - Power Cost Charge:** This is a charge to offset power costs incurred by the Department.
 - Energy CIP (Capital Improvement Project) Charge:** This is a charge to fund projects that improve energy efficiency.

HOW TO PAY YOUR BILL:

- Mail in your payment.
- In person at our office at 345 Kekūānā'oa St., Suite 20, in Hilo, or at our district offices in Waimea, Kona, and Ka'u.
- By Automatic Bill Payment from your checking account.
- On-line at payments.hawaii.gov.

Please allow sufficient time for your payment to reach us by the DUE DATE. We are not responsible for any payment which may be in transit on the due date. A late payment penalty of one-percent (1%) per month will be assessed on unpaid account balances outstanding for more than 30 days.

If payment is not received by the due date, a shut-off notice with a scheduled shut-off date will be mailed to the account holder. Contact us immediately if you are unable to pay amounts due by the due date. A disconnected service will not be restored until all amounts due are paid.

We assess a \$20 fee for all dishonored payments.

All water charges will continue to be your responsibility until you notify us to close your account.

ESTIMATED READINGS:

We try to read your meter each billing period. However, if it is not possible to do so, we will estimate your consumption based on your recent average water usage. Please help us by keeping your meter accessible and clear of cars, fences, walls, debris, foliage, and animals.



The Department of Water Supply is an equal opportunity provider and employer.

C. AGRICULTURAL USE RATES (per 1,000 gallons)

In addition to standby, power cost, and energy CIP charges, a consumption charge will be applied to all agricultural use customers as follows:

| | Effective July 1, 2015 | Effective July 1, 2016 | Effective July 1, 2017 | Effective July 1, 2018 | Effective July 1, 2019 |
|-----------------------|------------------------|------------------------|------------------------|------------------------|------------------------|
| 1 st Block | \$0.89 | \$0.91 | \$0.91 | \$0.91 | \$0.92 |
| 2 nd Block | 1.80 | 1.80 | 1.88 | 1.95 | 2.01 |
| 3 rd Block | 1.16 | 1.16 | 1.20 | 1.24 | 1.27 |

AGRICULTURAL BLOCK THRESHOLDS (gallons per month)

| Meter Size (inches) | 1 st Block | 2 nd Block | 3 rd Block |
|---------------------|-----------------------|-----------------------|-----------------------|
| All Sizes | 5,000 | 5,001 - 15,000 | >15,000 |

In order to qualify for agricultural rates, applicants shall file annually with the Department, a written application and furnish upon request, satisfactory proof (as determined by the Department), of engagement in agriculture, stock raising or dairy farming on a commercial basis, and that water used in addition to the above is limited to one dwelling. The Department reserves the right to limit or restrict water flow to agricultural users in the event of water shortage or in the event water service to domestic users is disrupted or lowered because of agricultural water use. Applicants shall install backflow preventers which shall be inspected and approved by the Department before water service is granted. Agricultural rates are not applicable to canneries, mills or markets or other establishments engaged in the conversion or treatment or packaging of agricultural products.

D. FIRE PROTECTION - MONTHLY STANDBY CHARGES*

For each connection of automatic fire sprinklers or other private fire protection, there shall be a standby charge per month, in addition to consumption, power cost, and energy CIP charges, based on the size of the connection as follows:

| Size of Service (inches) | Effective July 1, 2015 | Effective July 1, 2016 | Effective July 1, 2017 | Effective July 1, 2018 | Effective July 1, 2019 |
|--------------------------|------------------------|------------------------|------------------------|------------------------|------------------------|
| 2" | \$ 18.00 | \$ 18.00 | \$ 18.00 | \$ 18.00 | \$ 18.00 |
| 3" | 35.00 | 35.00 | 35.00 | 35.00 | 35.00 |
| 4" | 48.00 | 48.00 | 48.00 | 48.00 | 48.00 |
| 6" | 99.00 | 103.00 | 108.00 | 113.00 | 119.00 |
| 8" | 150.00 | 156.00 | 164.00 | 172.00 | 181.00 |

E. FIRE LINE OR FIRE SERVICE METERS - MONTHLY STANDBY CHARGES*

For each connection of combined fire & domestic services, there shall be a standby charge per month, in addition to consumption, power cost, and energy CIP charges, based on the larger size of the connection as follows:

| Size of Service (inches) | Effective July 1, 2015 | Effective July 1, 2016 | Effective July 1, 2017 | Effective July 1, 2018 | Effective July 1, 2019 |
|--------------------------|------------------------|------------------------|------------------------|------------------------|------------------------|
| 3" | \$ 172.00 | \$ 179.00 | \$ 188.00 | \$ 197.00 | \$ 207.00 |
| 4" | 283.00 | 294.00 | 309.00 | 324.00 | 340.00 |
| 6" | 561.00 | 583.00 | 612.00 | 643.00 | 675.00 |
| 8" | 895.00 | 931.00 | 978.00 | 1,027.00 | 1,078.00 |
| 10" | 1,288.00 | 1,340.00 | 1,407.00 | 1,477.00 | 1,551.00 |

...Water, Our Most Precious Resource...
 The Department of Water Supply is an equal opportunity provider and employer.

Department of Water Supply
 345 Kekūānā'oa Street, Suite #20
 Hilo, Hawaii 96720

Water Rates

Department of Water Supply

County of Hawai'i

345 Kekūānā'oa Street, Suite #20
 Hilo, Hawai'i 96720



Effective October 1, 2016

F. SERVICE LATERAL INSTALLATION CHARGES

Installation charge for service lateral connection with a 5/8-inch meter:

| | | Effective July 1, 2010 | |
|--------|--------------|------------------------|-------------|
| | | Same Side | Cross Road |
| County | Right-of-Way | \$ 3,000.00 | \$ 4,000.00 |
| State | Right-of-Way | 12,000.00 | 17,000.00 |

CONDITIONS:

- For special conditions such as concrete sidewalks, compaction tests, large cut or fill areas where additional work is required, additional charges, as determined by the Department, shall be added to the installation charges listed above.
- Deduct \$40 if no meter is required.

G. FACILITIES CHARGES

A facilities charge will be applicable to all new service connections based on the maximum size of the meter and type of service the service lateral can support or by the number of lots, dwelling units or equivalent units in the development, whichever cost is larger. The unit cost in determination of the facilities charges shall be \$5,500 for each additional lot, dwelling unit, or equivalent unit. The facilities charge is in addition to the service lateral installation charge. The schedule of facilities charges is as follows:

| Meter Size (inches) | | Effective July 1, 2010 |
|---------------------|-----------------------|------------------------|
| 5/8" | First Connection | \$ 1,190.00 |
| | Additional Connection | 5,500.00 |
| 1" | Each Connection | 13,750.00 |
| 1-1/4" | Each Connection | 27,500.00 |
| 2" | Each Connection | 44,000.00 |
| 3" | Each Connection | 82,500.00 |
| 4" | Each Connection | 137,500.00 |
| 6" | Each Connection | 275,000.00 |
| 8" | Each Connection | 495,000.00 |
| 10" | Each Connection | 797,500.00 |
| 12" | Each Connection | 1,182,500.00 |

H. TEMPORARY SERVICE ON HYDRANT CHARGES

Each applicant for a temporary connection of a meter to a fire hydrant shall be charged an initial payment, to be set periodically by the Department, in addition to consumption, standby, power cost, and energy CIP charges. Service shall be limited to a period not longer than 180 calendar days. The Department reserves the right to deny any application or remove any temporary connection at any time.

I. STANDPIPE CHARGES

New customers obtaining water service from Department of Water Supply standpipe facilities shall be charged an initial payment and a proportional cost of the standpipe facility on a monthly basis. These charges are as follows and are in addition to consumption, standby, power cost, and energy CIP charges:

| | Effective July 1, 2015 | Effective July 1, 2016 | Effective July 1, 2017 | Effective July 1, 2018 | Effective July 1, 2019 |
|--|------------------------|------------------------|------------------------|------------------------|------------------------|
| Initial Payment | | | | | |
| Meter Size | | | | | |
| 5/8" | \$ 152.00 | \$ 158.00 | \$ 166.00 | \$ 174.00 | \$ 183.00 |
| 1" | 306.00 | 318.00 | 334.00 | 351.00 | 369.00 |
| 1-1/4" | 382.00 | 397.00 | 417.00 | 438.00 | 460.00 |
| 2" | 458.00 | 476.00 | 500.00 | 525.00 | 551.00 |
| Amortized Installation Cost - Monthly | | | | | |
| Meter Size | | | | | |
| 5/8" | \$ 10.00 | \$ 10.00 | \$ 10.00 | \$ 10.00 | \$ 10.00 |
| 1" | 20.00 | 20.00 | 20.00 | 20.00 | 20.00 |
| 1-1/4" | 25.00 | 25.00 | 25.00 | 25.00 | 25.00 |
| 2" | 29.00 | 29.00 | 29.00 | 29.00 | 29.00 |

J. POWER COST CHARGES (per 1,000 gallons)

All water use shall be subject to the imposition of a Power Cost Charge in addition to consumption, standby, and energy CIP charges. The Department shall calculate the rate based on actual power costs and consumption every two months or for the period since the last revision to the power cost charge. Current and historic power cost charges are as follows:

| Effective Date | Power Cost Charges |
|-------------------|--------------------|
| October 1, 2016 | \$1.61 |
| June 1, 2016 | \$1.70 |
| February 1, 2016 | \$1.81 |
| September 1, 2015 | \$1.85 |

K. ENERGY CIP CHARGES (per 1,000 gallons)

All water use shall be subject to the imposition of an Energy CIP Charge in addition to consumption, standby, and power cost charges. The rate shall be adjusted annually in order to fund projects designed to improve the Department's energy efficiency. The current energy CIP charge is as follows:

| Effective Date | Energy CIP Charge |
|----------------|-------------------|
| July 1, 2016 | \$0.05 |

EXHIBIT "F"

2 bath dwelling

| | | |
|---------------|------------|----------|
| water closet | 2 x 1.7 FU | = 3.4 FU |
| lavatory | 2 x 0.6 FU | = 1.2 FU |
| Tub/shower | 2 x 1.6 FU | = 3.2 FU |
| washing mach. | 1 x 2 FU | = 2 FU |
| laundry tray | 1 x 2 FU | = 2 FU |
| hose bibbs | 4 x 1 FU | = 4 FU |
| kitchen sink | 1 x 1.6 FU | = 1.6 FU |
| dishwasher | 1 x 2 FU | = 2 FU |

Total 19.4 FU

This equates to 15 gpm

4-1/2 bath dwelling (no pool or automatic irrigation)

| | | |
|---------------|--------------|--------|
| water closet | 5 x 1.7 FU = | 8.5 FU |
| lavatory | 5 x 0.6 FU = | 3.0 FU |
| Tub/shower | 4 x 1.6 FU = | 6.4 FU |
| washing mach. | 1 x 2 FU = | 2.0 FU |
| laundry tray | 1 x 2 FU = | 2.0 FU |
| hose bibbs | 6 x 1 FU = | 6.0 FU |
| kitchen sink | 1 x 1.6 FU = | 1.6 FU |
| dishwasher | 1 x 2 FU = | 2.0 FU |

Total 31.5 FU

This equates to 20 gpm

Water Meter Capacities

| Meter | Flow Requirements | Conversion of gpm to Fixture Unit Count |
|---------|-------------------|---|
| Size | (gpm) | Fixture Unit (FU) |
| 5/8" | 0 - 20 | Min. 20 - 30 |
| 3/4" | 21 - 30 | 31 - 53 |
| 1" | 31 - 50 | 54 - 130 |
| 1- 1/2" | 51 - 100 | 131 - 400 |
| 2" | 101 - 160 | 401 - 700 |
| 3" | 161 - 320 | 701 - 1900 |
| 4" | 321 - 500 | 1901 - 2700 |

SPECIFICATION SHEET



Series 406

Detector Check for Automatic Fire Sprinkler Systems

Size: 2" (50mm)

The FEBCO Series 406 Detector Check is designed for automatic fire sprinkler systems.

Features

- Meter detects leakage and/or theft of water from Automatic Fire Sprinkler Systems
- Can be installed horizontally or vertically (up or down)
- Center-stem-guided, spring-loaded check for more positive seating
- Replaceable bronze seat ring
- Reversible seat disc for ease of service
- Bronze body and cover
- End Detail – 2 Bolt Meter Flange

Operation

In a non-flowing condition, the mainline check and by-pass check are closed and the meter is stopped. When water begins to flow, the by-pass check opens and the meter begins to register. When the pressure drop across the valve approximates 1.5psi (10.3 kPa), the mainline check opens and allows full flow of water. The by-pass meter and check remain operating and open at all flow rates.

Specifications

The Detector Check 2" (50mm) mainline valve shall consist of an internally spring loaded "Y" pattern check valve having a bronze body, bronze replaceable bushing in the cover, a bronze replaceable seat ring, stainless steel spring and delrin disc holder to insure positive check seating.

The bypass line shall consist of a ¾" (20mm) IPS shut-off valve, bronze totalizing water meter and a bronze single check valve in series. The unit is also available without bypass.

The assembly shall be rated to 175psi working pressure and water temperatures from 32°F to 110°F (0°C to 43°C).

NOTICE

Inquire with governing authorities for local installation requirements

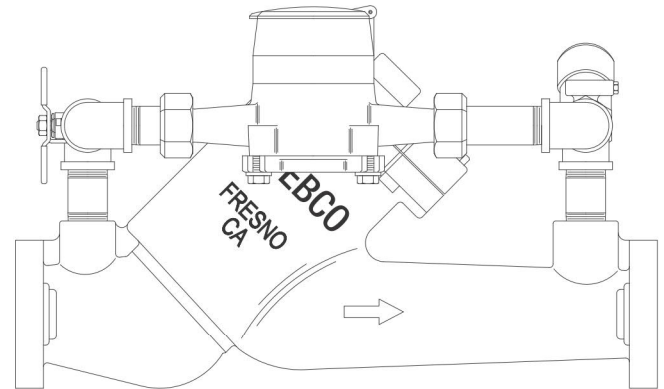

406

Pressure – Temperature

| | |
|----------------------------|---|
| Sizes: | Mainline: 2" (50mm) By-pass: ¾" (20mm) IPS |
| Maximum Working Pressure: | 175psi (12.1 bar) |
| Hydrostatic Test Pressure: | 350psi (24.1 bar) |
| Temperature Range: | 32°F to 110°F (0°C - 43°C) |

Materials

| | |
|------------------|--|
| Main Valve Body: | Bronze |
| Seat Ring: | Bronze |
| Disc Holder: | Delrin |
| Spring: | Stainless Steel |
| By-pass Meter: | Bronze Totalizing Water Meter Optional (gpm or cfm) |

⚠ WARNING

It is illegal to use this product in any plumbing system providing water for human consumption, such as drinking or dishwashing, in the United States. Before installing standard material product, consult your local water authority, building and plumbing codes.

Job Name _____

Job Location _____

Engineer _____

Approval _____

Contractor _____

Approval _____

Contractor's P.O. No. _____

Representative _____

FEBCO product specifications in U.S. customary units and metric are approximate and are provided for reference only. For precise measurements, please contact FEBCO. FEBCO reserves the right to change or modify product design, construction, specifications, or materials without prior notice and without incurring any obligation to make such changes and modifications on FEBCO products previously or subsequently sold.

Capacity

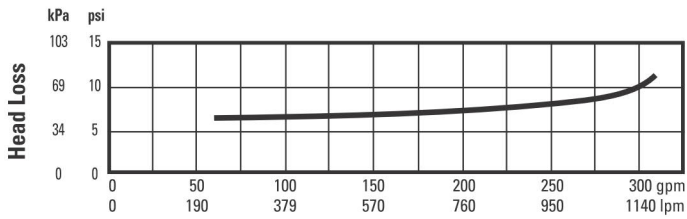

NOTE:
Velocities are calculated for flows in Schedule 40 steel pipe.

Dimensions

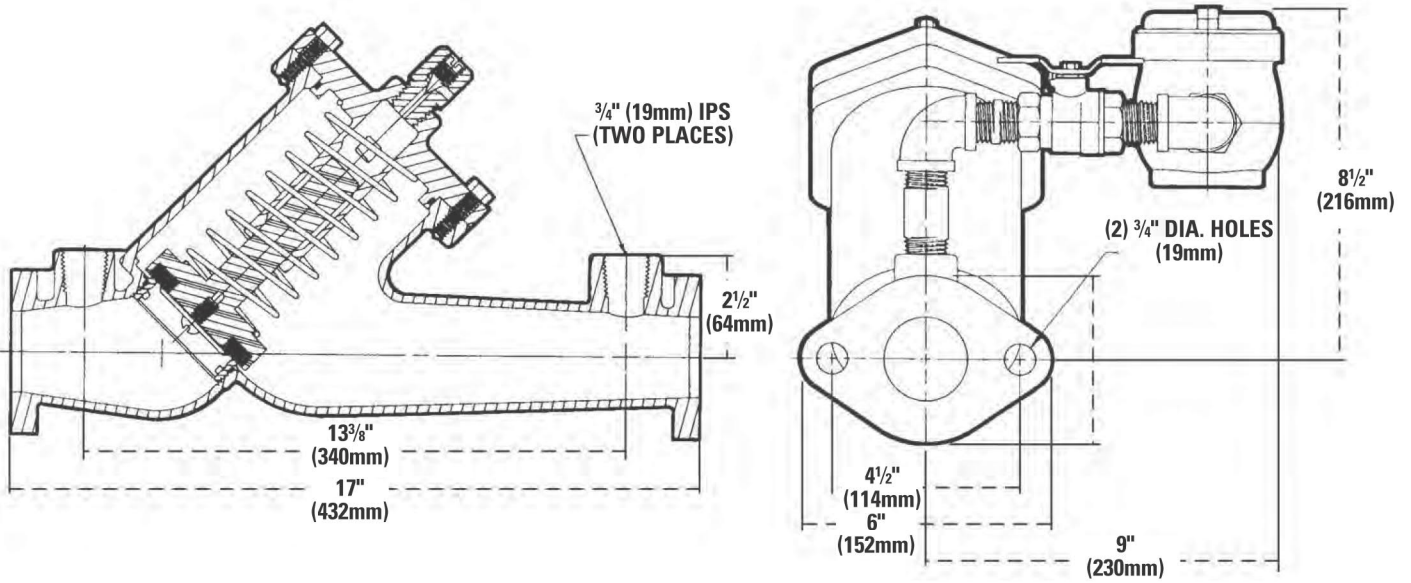

A Watts Water Technologies Company

USA: Tel: (800) 767-1234 • Fax: (800) 788-4491 • FEBCOonline.com

Canada: Tel: (905) 332-4090 • Fax: (905) 332-7068 • FEBCOonline.ca

Latin America: (52) 81-1001-8600 • Fax: (52) 81-8000-7091 • FEBCOonline.com

BACKFLOW PREVENTION PRODUCTS PRICE LIST

Effective June 1, 2012

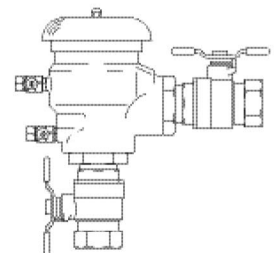
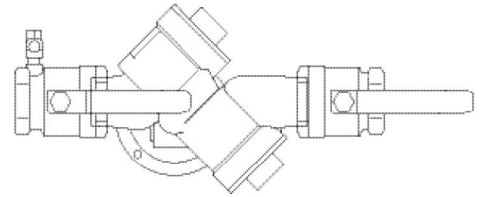
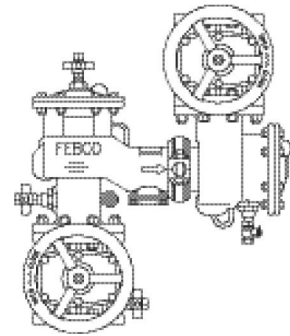

FEBCO BACKFLOW PREVENTION – WHOLE GOODS LIST PRICES

MasterSeries (2½" - 10") Body Styles/Product Matrix

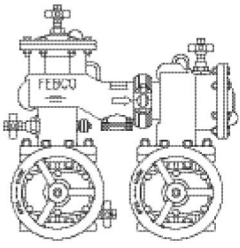
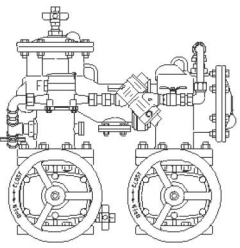
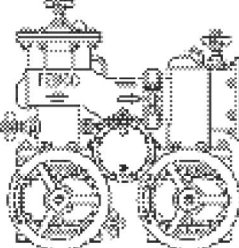
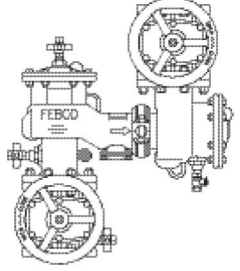
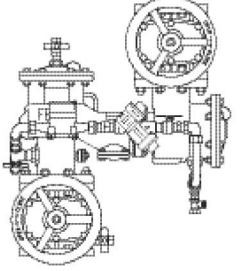
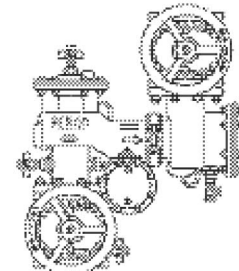
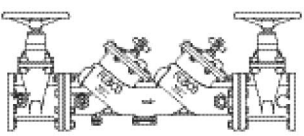
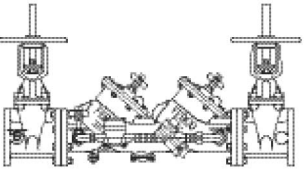
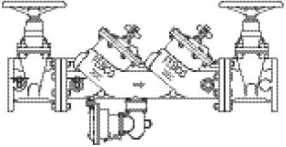
| | Double Check Assembly | Double Check Detector Assembly | Reduced Pressure Assembly |
|-----------------------------|--|---|--|
| "N" - Shape | Model 870V  | Model 876V  | Model 880V  |
| Vertical | Model 870V  | Model 876V  | Model 880V  |
| Conventional In-Line | Model 850  | Model 856  | Model 860  |

MasterSeries (2½" - 10") Available Shutoffs¹

| FEBCO MasterSeries | In-Line Configuration | | "N"-Shape Configuration | | Vertical Configuration | |
|--------------------------------|-----------------------|-------------------|-------------------------|-------------------|------------------------|-------------------|
| Type | Model | Available Shutoff | Model | Available Shutoff | Model | Available Shutoff |
| Double Check Assembly | 850 | NRS/OSY/LG | 870V | NRS/OSY/LG | 870V | NRS/OSY/LG |
| Double Check Detector Assembly | 856 | OSY/LG | 876V | OSY/LG | 876V | OSY/LG |
| Reduced Pressure Assembly | 860 | NRS/OSY/LG | 880V | NRS/OSY/LG | 880V | NRS/OSY/LG |

Supersedes all other price lists / Prices subject to change / Weights are estimated

¹ Grooved ends available on OS&Y gate valves in some models & sizes. Expect larger lead times.

FEBCO BACKFLOW PREVENTION – WHOLE GOODS LIST PRICES

Table of Contents

| | |
|---|----|
| How to Order | 3 |
| Double Check Assemblies - DC | |
| 870V (2½" - 10") | 4 |
| 850 (2½" - 10") | 4 |
| 805YD (2½" - 10") | 4 |
| 850/850U (½" - 2") | 5 |
| Double Check Detector Assemblies - DCDA | |
| 876V (2½" - 10")..... | 5 |
| 856 (2½" - 10")..... | 5 |
| 806YD (3" - 10") | 6 |
| Reduced Pressure Assemblies - RP | |
| 880V (2½" - 10")..... | 6 |
| 860 (2½" - 10")..... | 6 |
| 825YD (2½" - 10") | 6 |
| 826YD (2½" - 10") RPDA | 7 |
| 860/860U (½" - 2") | 7 |
| 825Y (¾" - 2")..... | 7 |
| 825YA (Angle Pattern) (¾" - 2")..... | 8 |
| Vacuum Breaker Assemblies | |
| 765 (½" - 2")..... | 8 |
| 730D Hose Bibb (¾") | 8 |
| 710/715 (½" - 2") | 8 |
| Dual Check | |
| 810 (¾" - 1) | 9 |
| Detector Check Assemblies | |
| 406 (2") | 9 |
| 800 (4" - 10")..... | 9 |
| Accessories | |
| DuraCheck to MasterSeries Spacer | 10 |
| MasterSeries Valve Setters | 10 |
| Resilient Wedge Gate Valves | 10 |
| Full Port / Union End Ball Valves | 11 |
| Full Port Test Cocks..... | 11 |
| Air Gap Drains..... | 12 |
| Model 800 By-Pass Kit..... | 12 |
| Test Kits..... | 12 |
| Strainers | |
| 758 "Y" Strainer (2½" - 10") | 13 |
| 650 "Y" Strainer (½" - 2")..... | 13 |
| Warranty | 14 |

How To Order

1. Determine the type of valve assembly required, such as a Double Check Assembly (DC).
2. Determine size, options, and accessories.
3. Use the following pages to determine the part number, list price and shipping weight.
4. Contact your local representative or visit our website at www.FEBCOonline.com for up-to-date approvals.
5. Prices subject to change without notice.
6. Weights are estimated.

FEBCO BACKFLOW PREVENTION – WHOLE GOODS LIST PRICES

MasterSeries Model 870V Double Check Assembly

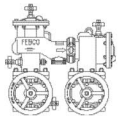

N-Shape Configuration

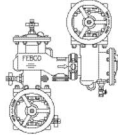

Vertical Configuration

| 870V | With NRS Gate Valves | | | With OSY Gate Valves | | | Less Gates | | |
|------|----------------------|-----------|----------------|----------------------|-----------|----------------|------------|-----------|----------------|
| Size | Part # | List \$ | Ship Wt. (lbs) | Part # | List \$ | Ship Wt. (lbs) | Part # | List \$ | Ship Wt. (lbs) |
| 2½" | 2132 | 2,214.50 | 284 | 2139 | 2,832.60 | 295 | 2125 | 1,807.80 | 164 |
| 3" | 2133 | 2,678.00 | 306 | 2140 | 2,884.00 | 335 | 2126 | 1,878.20 | 165 |
| 4" | 2134 | 3,327.00 | 430 | 2141 | 3,502.10 | 465 | 2127 | 2,730.10 | 228 |
| 6" | 2135 | 5,356.00 | 683 | 2142 | 5,582.60 | 650 | 2128 | 3,985.90 | 311 |
| 8" | 2136 | 10,712.10 | 914 | 2143 | 11,021.10 | 950 | 2129 | 7,967.10 | 425 |
| 10" | 2137 | 14,420.10 | 1490 | 2144 | 14,935.10 | 1590 | 2130 | 11,091.30 | 68 |

MasterSeries Model 850 Double Check Assembly (upgrade from Model 805YD*)

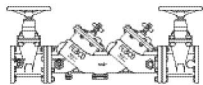

Horizontal Installation

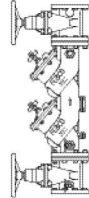

Vertical Installation

| 850 | With NRS Gate Valves | | | With OSY Gate Valves | | | Less Gates | | |
|------|----------------------|-----------|----------------|----------------------|-----------|----------------|------------|-----------|----------------|
| Size | Part # | List \$ | Ship Wt. (lbs) | Part # | List \$ | Ship Wt. (lbs) | Part # | List \$ | Ship Wt. (lbs) |
| 2½" | 1132 | 2,420.50 | 278 | 1139 | 2,667.80 | 283 | 1125 | 1,656.20 | 168 |
| 3" | 1133 | 2,575.00 | 303 | 1140 | 2,884.00 | 321 | 1126 | 1,749.00 | 180 |
| 4" | 1134 | 4,738.10 | 397 | 1141 | 3,296.10 | 421 | 1127 | 2,439.90 | 183 |
| 6" | 1135 | 3,160.50 | 654 | 1142 | 5,041.90 | 654 | 1128 | 3,588.10 | 324 |
| 8" | 1136 | 8,652.10 | 980 | 1143 | 9,373.10 | 1008 | 1129 | 7,340.60 | 435 |
| 10" | 1137 | 12,617.70 | 1080 | 1144 | 13,699.10 | 1108 | 1130 | 10,847.20 | 535 |

* See Accessory Section for Spool Adapter to retrofit from Model 805YD.

DuraCheck Model 805YD Double Check Assembly

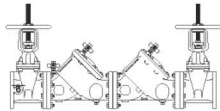

Horizontal Installation

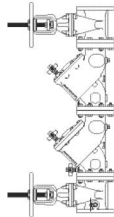

Vertical Installation

| 805YD | With OSY Gate Valves | | |
|-------|----------------------|-----------|----------------|
| Size | Part # | List \$ | Ship Wt. (lbs) |
| 3" | 805KRO | 4,983.30 | 312 |
| 4" | 805MRO | 6,436.60 | 476 |
| 6" | 805RRO | 9,169.90 | 815 |
| 8" | 805SRO | 15,065.80 | 1089 |

* Limited Availability. See Accessory Section for Spool Adapter to retrofit to Model 850.

CF-Contact Factory

| 805YD | With NRS Gate Valves | | | With OSY Gate Valves | | | Less Gates | | |
|-------|----------------------|-----------|----------------|----------------------|-----------|----------------|------------|-----------|----------------|
| Size | Part # | List \$ | Ship Wt. (lbs) | Part # | List \$ | Ship Wt. (lbs) | Part # | List \$ | Ship Wt. (lbs) |
| 10" | 805TRN | 12,777.30 | 1460 | 805TRO | 15,439.90 | 1700 | 805TLG | 10,356.70 | 850 |

FEBCO BACKFLOW PREVENTION – WHOLE GOODS LIST PRICES

MasterSeries Model 850 / 850U Double Check Assembly

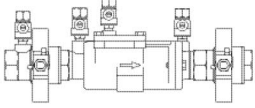

| 850/850U | 850 (With Ball Valves) | | | 850U (with Union Ball Valves) | | |
|----------|------------------------|---------|----------------|-------------------------------|---------|----------------|
| Size | Part # | List \$ | Ship Wt. (lbs) | Part # | List \$ | Ship Wt. (lbs) |
| 1/2" | 1111 | 211.50 | 5 | 2611 | 266.80 | 6 |
| 3/4" | 1112 | 226.60 | 6 | 2612 | 346.10 | 7 |
| 1" | 1113 | 255.40 | 7 | 2613 | 384.20 | 10 |
| 1 1/4" | 1114 | 466.50 | 8 | 2614 | 675.60 | 18 |
| 1 1/2" | 1115 | 474.90 | 19 | 2615 | 741.60 | 21 |
| 2" | 1116 | 545.90 | 21 | 2616 | 873.40 | 27 |

MasterSeries Model 876V Double Check Detector Assembly

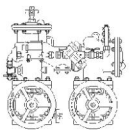

N-Shape Configuration

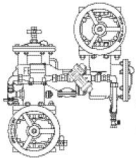

Vertical Configuration

| 876V | With OSY Valves - Neptune Gal. Meters | | | Less Gate - Neptune Gal. Meters | | |
|--------|---------------------------------------|-----------|----------------|---------------------------------|-----------|----------------|
| Size | Part # | List \$ | Ship Wt. (lbs) | Part # | List \$ | Ship Wt. (lbs) |
| 2 1/2" | 22391 | 4,532.00 | 303 | 22251 | | 190 |
| 3" | 22401 | 4,624.80 | 334 | 22261 | 3,508.10 | 205 |
| 4" | 22411 | 4,892.60 | 458 | 22271 | 4,042.20 | 235 |
| 6" | 22421 | 6,870.30 | 665 | 22281 | 6,048.20 | 390 |
| 8" | 22431 | 12,205.60 | 955 | 22291 | 10,709.00 | 500 |
| 10" | 22441 | 17,489.50 | 1590 | 22301 | 14,825.10 | 715 |

MasterSeries Model 856 Double Check Detector Assembly (upgrade from Model 806YD)*

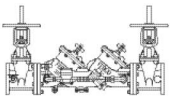

Horizontal Installation

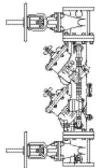

Vertical Installation

| 856 | With OSY Valves - Neptune Gal. Meters | | | Less Gate - Neptune Gal. Meters | | |
|--------|---------------------------------------|-----------|----------------|---------------------------------|-----------|----------------|
| Size | Part # | List \$ | Ship Wt. (lbs) | Part # | List \$ | Ship Wt. (lbs) |
| 2 1/2" | 12391 | 4,500.20 | 291 | 12251 | 3,388.80 | 174 |
| 3" | 12401 | 5,500.20 | 325 | 12261 | 4,089.20 | 182 |
| 4" | 12411 | 5,654.80 | 439 | 12271 | 3,708.10 | 202 |
| 6" | 12421 | 7,313.10 | 650 | 12281 | 5,036.70 | 328 |
| 8" | 12431 | 13,235.70 | 967 | 12291 | 9,321.60 | 459 |
| 10" | 12441 | 18,056.10 | 1067 | 12301 | 13,493.20 | 559 |

* See Accessory Section for Spool Adapter to retrofit from Model 806YD.

FEBCO BACKFLOW PREVENTION – WHOLE GOODS LIST PRICES

Model 806YD Double Check Detector Assembly

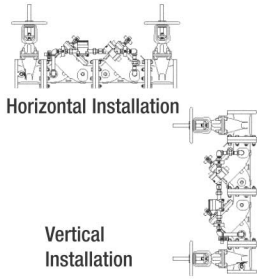

| 806YD | | With OSY Gate Valves - Neptune Gal. Meters | | |
|-------|-----------|--|----------------|--|
| Size | Part # | List \$ | Ship Wt. (lbs) | |
| 3" | 806KRO00A | 7,151.00 | 341 | |
| 4" | 806MRO00A | 7,477.20 | 504 | |
| 6" | 806RRO00A | 10,713.90 | 832 | |
| 8" | 806SRO00A | 16,463.20 | 1150 | |
| 10" | 806TRO00A | 16,770.40 | 1800 | |

* Limited Availability. See Accessory Section for Spool Adapter to retrofit to Model 856.

MasterSeries Model 880V Reduced Pressure Assembly

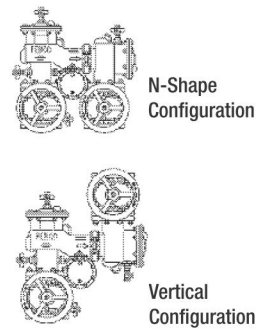

| 880V | With NRS Gate Valves | | | With OSY Gate Valves | | | Less Gates | | |
|------|----------------------|-----------|----------------|----------------------|-----------|----------------|------------|-----------|----------------|
| Size | Part # | List \$ | Ship Wt. (lbs) | Part # | List \$ | Ship Wt. (lbs) | Part # | List \$ | Ship Wt. (lbs) |
| 2½" | 2332 | 2,987.00 | 297 | 2339 | 3,296.10 | 290 | 2325 | 2,719.40 | 180 |
| 3" | 2333 | 3,399.00 | 332 | 2340 | 3,687.40 | 328 | 2326 | 3,026.50 | 185 |
| 4" | 2334 | 4,532.00 | 435 | 2341 | 5,026.50 | 445 | 2327 | 4,005.90 | 220 |
| 6" | 2335 | 7,158.70 | 650 | 2342 | 7,725.10 | 680 | 2328 | 6,346.80 | 390 |
| 8" | 2336 | 14,729.10 | 943 | 2343 | 15,450.20 | 960 | 2329 | 10,811.80 | 450 |
| 10" | 2337 | 19,879.20 | 1500 | 2344 | 21,218.20 | 1535 | 2330 | 15,517.00 | 712 |

MasterSeries Model 860 Reduced Pressure Assembly (upgrade from Model 825YD)*

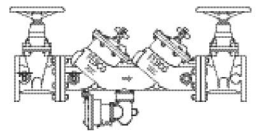

| 860 | With NRS Gate Valves | | | With OSY Gate Valves | | | Less Gates | | |
|------|----------------------|-----------|----------------|----------------------|-----------|----------------|------------|-----------|----------------|
| Size | Part # | List \$ | Ship Wt. (lbs) | Part # | List \$ | Ship Wt. (lbs) | Part # | List \$ | Ship Wt. (lbs) |
| 2½" | 1332 | 2,812.00 | 313 | 1339 | 3,193.00 | 333 | 1325 | 2,488.90 | 196 |
| 3" | 1333 | 3,193.00 | 343 | 1340 | 3,450.60 | 348 | 1326 | 2,764.90 | 225 |
| 4" | 1334 | 4,429.10 | 450 | 1341 | 4,789.60 | 457 | 1327 | 3,600.00 | 236 |
| 6" | 1335 | 6,592.00 | 660 | 1342 | 7,364.60 | 695 | 1328 | 5,584.50 | 344 |
| 8" | 1336 | 14,059.70 | 1004 | 1343 | 14,626.20 | 1034 | 1329 | 9,743.70 | 518 |
| 10" | 1337 | 18,952.20 | 1104 | 1344 | 19,879.20 | 1134 | 1330 | 14,562.40 | 618 |

* See Accessory Section for Spool Adapter to retrofit from Model 825YD.

DuraCheck Model 825YD Reduced Pressure Assembly

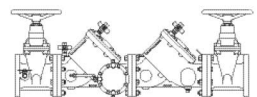

| 825YD | With NRS Gate Valves | | | With OSY Gate Valves | | |
|-------|----------------------|-----------|----------------|----------------------|-----------|----------------|
| Size | Part # | List \$ | Ship Wt. (lbs) | Part # | List \$ | Ship Wt. (lbs) |
| 2½" | 825JRN | 4,938.10 | 245 | 825JRO | 5,405.20 | 277 |
| 3" | 825KRN | 5,405.20 | 324 | 825KRO | 5,732.80 | 322 |
| 4" | 825MRN | 6,669.30 | 485 | 825MRO | 7,448.40 | 460 |
| 6" | 825RRN | 11,204.90 | 762 | 825RRO | 11,380.60 | 834 |
| 8" | 825SRN | 16,554.10 | 1122 | 825SRO | 17,543.40 | 1145 |
| 10" | 825TRN | 17,585.20 | 1500 | 825TRO | 18,477.80 | 1700 |

* Limited Availability. See Accessory Section for Spool Adapter to retrofit to Model 860.

Supersedes all other price lists / Prices subject to change / Weights are estimated

¹ Grooved ends available on OS&Y gate valves in some models & sizes. Expect larger lead times.

FEBCO BACKFLOW PREVENTION – WHOLE GOODS LIST PRICES

DuraCheck Model 826YD Reduced Pressure Detector Assembly

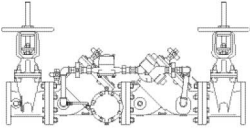

| 826YD | | With OSY Gate Valves | | Less Gates | | |
|-------|-----------|----------------------|----------------|------------|-----------|----------------|
| Size | Part # | List \$ | Ship Wt. (lbs) | Part # | List \$ | Ship Wt. (lbs) |
| 2½" | 826JR000A | 5,375.70 | 297 | 826JLG00A | 3,842.40 | 184 |
| 3" | 826KR000A | 5,660.20 | 390 | 826KLG00A | 4,207.80 | 225 |
| 4" | 826MR000A | 6,621.60 | 530 | 826MLG00A | 5,489.50 | 300 |
| 6" | 826RR000A | 9,796.90 | 757 | 826RLG00A | 7,530.80 | 470 |
| 8" | 826SR000A | 17,853.50 | 1130 | 826SLG00A | 12,825.30 | 562 |
| 10" | 826TR000A | 24,700.60 | 1770 | 826TLG00A | 16,993.70 | 935 |

MasterSeries Model 860 / 860U Reduced Pressure Assembly

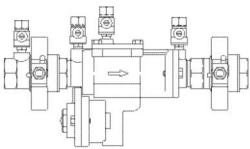

| 860/860U | | 860 (With Ball Valves) | | 860U (with Union Ball Valves) | | |
|----------|--------|------------------------|----------------|-------------------------------|---------|----------------|
| Size | Part # | List \$ | Ship Wt. (lbs) | Part # | List \$ | Ship Wt. (lbs) |
| ½" | 1311 | 289.40 | 4 | 2811 | 333.60 | 10 |
| ¾" | 1312 | 348.20 | 9 | 2812 | 407.20 | 10 |
| 1" | 1313 | 408.10 | 10 | 2813 | 435.60 | 12 |
| 1¼" | 1314 | 608.20 | 20 | 2814 | 705.30 | 22 |
| 1½" | 1315 | 681.80 | 23 | 2815 | 802.40 | 25 |
| 2" | 1316 | 765.10 | 28 | 2816 | 875.00 | 30 |

Model 825Y Reduced Pressure Assembly

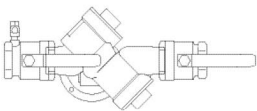

| 825Y | | With Ball Valves | | |
|------|--------|------------------|----------------|--|
| Size | Part # | List \$ | Ship Wt. (lbs) | |
| ¾" | 825DBV | 686.70 | 13 | |
| 1" | 825EBV | 824.00 | 15 | |
| 1¼" | 825FBV | 1,280.30 | 17 | |
| 1½" | 825GBV | 1,334.10 | 31 | |
| 2" | 825HBV | 1,667.60 | 35 | |

FEBCO BACKFLOW PREVENTION – WHOLE GOODS LIST PRICES

Model 825YA Reduced Pressure Assembly

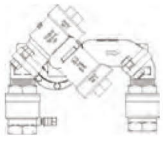

Standard Configuration

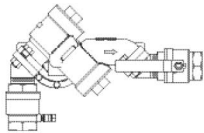

Inlet Flow Up/
Outlet Flow Horizontal

| 825YA | | With Ball Valves | |
|--------|----------|------------------|----------------|
| Size | Part # | List \$ | Ship Wt. (lbs) |
| 3/4" | 825DBV70 | 705.60 | 17 |
| 1" | 825EBV70 | 832.20 | 18 |
| 1 1/2" | 825GBV70 | 1,367.90 | 38 |
| 2" | 825HBV70 | 1,627.40 | 43 |

Model 765 Pressure Vacuum Breaker

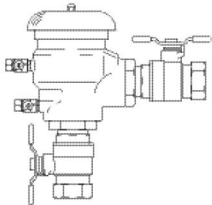

| 765 | | 765 (With Ball Valves) | | 765 (with Union Ball Valves) | | |
|--------|--------|------------------------|----------------|------------------------------|---------|----------------|
| Size | Part # | List \$ | Ship Wt. (lbs) | Part # | List \$ | Ship Wt. (lbs) |
| 1/2" | 765CBV | 212.80 | 4 | 765CUB | 225.60 | 5 |
| 3/4" | 765DBV | 212.80 | 5 | 765DUB | 225.60 | 6 |
| 1" | 765EBV | 219.80 | 7 | 765EUB | 233.50 | 10 |
| 1 1/4" | 765FBV | 382.70 | 9 | 765FUB | 407.20 | 19 |
| 1 1/2" | 765GBV | 461.10 | 18 | 765GUB | 490.50 | 20 |
| 2" | 765HBV | 505.30 | 22 | 765HUB | 534.60 | 28 |

Model 730D Hose Bibb Vacuum Breaker

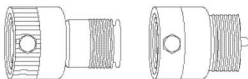

| 730DSB | | Hose Bibb Vacuum Breaker | | |
|-------------|--------------------------|--------------------------|----------------|--|
| Size | Part # | List \$ | Ship Wt. (lbs) | |
| 3/4" Brass | 730DSB (Self Draining) | 42.30 | 1 | |
| 3/4" Brass | 730DMB (Manual Draining) | 18.60 | 1 | |
| 3/4" Chrome | 730DMC (Manual Draining) | 18.60 | 1 | |

Model 710/715 Atmospheric Vacuum Breaker

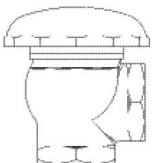

| 710/715 | | Atmospheric Vacuum Breaker | | |
|---------|--------|----------------------------|----------------|--|
| Size | Part # | List \$ | Ship Wt. (lbs) | |
| 1/2" | 715C | 54.50 | 1 | |
| 3/4" | 715D | 57.70 | 1 | |
| 1" | 710E | 98.90 | 2 | |
| 1 1/4" | 710F | 160.60 | 3 | |
| 1 1/2" | 710G | 190.60 | 4 | |
| 2" | 710H | 283.20 | 5 | |

FEBCO BACKFLOW PREVENTION – WHOLE GOODS LIST PRICES

Model 810 Dual Check

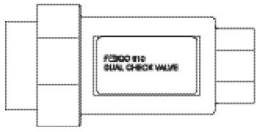

FPT = Female Iron Pipe Thread
MPT = Male Iron Pipe Thread

| 810 | | Dual Check | | |
|------|---------|-------------------------|---------|----------------|
| Size | Part # | Description | List \$ | Ship Wt. (lbs) |
| 3/4" | 810DA11 | FPT x FPT, Union Inlet | 72.10 | 1.5 |
| 3/4" | 810DB21 | MPT x FPT, Union Outlet | 72.10 | 1.5 |
| 1" | 810EB11 | FPT x FPT, Union Outlet | 87.50 | 1.5 |
| 1" | 810EB21 | MPT x FPT, Union Outlet | 87.50 | 1.5 |

* Contact Factory

Model 406 and 800 Detector Checks

Model 406

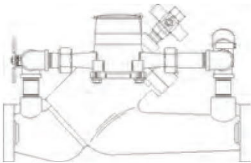

Model 800

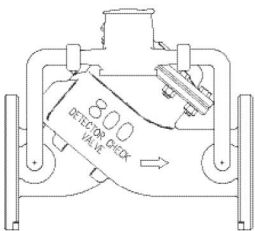

| Model | Size | Bypass | | No Bypass | Gal Meter | CF Meter |
|-------|------|--------|------------|-----------|-----------|----------|
| 406 | 2" | 3/4" | Part # | 406HND | 406HRD11 | 406HRD13 |
| | | | List Price | 2,712.40 | 3,176.00 | 3,176.00 |
| | | | Ship Wt. | 29 | 33 | 33 |
| 800 | 4" | 3/4" | Part # | 800M5111 | 800M2211 | 800M2311 |
| | | | List Price | 1,454.80 | 1,864.00 | 1,864.00 |
| | | | Ship Wt. | 90 | 138 | 138 |
| 800 | 4" | 1" | Part # | 800M | N/A | N/A |
| | | | List Price | 1,524.00 | N/A | N/A |
| | | | Ship Wt. | 90 | N/A | N/A |
| 800 | 6" | 3/4" | Part # | 800R5111 | 800R2211 | 800R2311 |
| | | | List Price | 1,846.40 | 2,477.20 | 2,477.20 |
| | | | Ship Wt. | 145 | 220 | 220 |
| 800 | 6" | 1" | Part # | 800R | N/A | N/A |
| | | | List Price | 1,651.20 | N/A | N/A |
| | | | Ship Wt. | 145 | N/A | N/A |
| 800 | 8" | 3/4" | Part # | 800S5111 | 800S2211 | 800S2311 |
| | | | List Price | 3,344.60 | 3,612.50 | 3,613.50 |
| | | | Ship Wt. | 245 | 347 | 347 |
| 800 | 8" | 1" | Part # | 800S | N/A | N/A |
| | | | List Price | 3,344.60 | N/A | N/A |
| | | | Ship Wt. | 245 | N/A | N/A |
| 800 | 10" | 3/4" | Part # | N/A | 800T2211 | 800T2311 |
| | | | List Price | N/A | 6,410.50 | 6,410.50 |
| | | | Ship Wt. | N/A | 495 | 495 |
| 800 | 10" | 1" | Part # | 800T | N/A | N/A |
| | | | List Price | 5,182.80 | N/A | N/A |
| | | | Ship Wt. | 393 | N/A | N/A |

FEBCO BACKFLOW PREVENTION – ACCESSORIES LIST PRICES

Spool Adapter Kits

For use when retrofitting from Duracheck to MasterSeries Models.

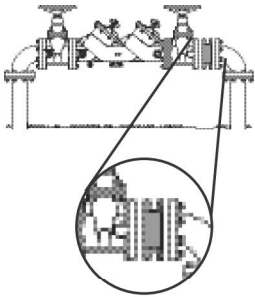

| Spacer | Duracheck to Inline MasterSeries Spool Adapter Kit | | |
|--------|--|----------|----------------|
| Size | Part # | List \$ | Ship Wt. (lbs) |
| 4" | 905523 | 854.90 | CF |
| 6" | 905524 | 9,52.70 | CF |
| 8" | 905525 | 1,349.40 | CF |

CF-Contact Factory

Resilient Wedge Gate Valve

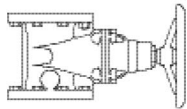

NRS Gate Valve

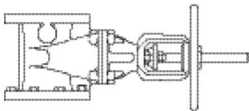

OSY Gate Valve

| RW Gates | | NRS RW Gate Valves | | OSY RW Gate Valves | | |
|----------|--------|--------------------|----------------|--------------------|----------|----------------|
| Size | Part # | List \$ | Ship Wt. (lbs) | Part # | List \$ | Ship Wt. (lbs) |
| 2½" | 781005 | 687.50 | 40 | 780891 | 1,053.30 | 50 |
| 3" | 781006 | 705.60 | 50 | 780893 | 1,120.20 | 89 |
| 4" | 781007 | 901.30 | 66 | 780895 | 1,127.80 | 100 |
| 6" | 781008 | 1,272.10 | 124 | 780897 | 1,568.30 | 151 |
| 8" | 781009 | 2,155.30 | 172 | 780899 | 2,709.00 | 233 |
| 10" | 781010 | 3,780.10 | 277 | 780-901 | 4,089.20 | 391 |

The resilient wedge gate valve consists of a cast iron, epoxy coated body, with fully rubber encapsulated wedge. The valve body is flanged and rated to 200 PSI and tapped for test cock requirements. The non-rising stem gate valve is tested to AWWA (C509 NRS). The outside stem and yoke gate valve is UL Listed and FM Approved. Customer needs to specify the gate valve manufacturer required on the project.

FEBCO BACKFLOW PREVENTION – ACCESSORIES LIST PRICES

Full Port Ball Valve

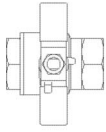

Model 622F
Model 622FT (Tapped)

| 622F/FT | | 622F (Non Tapped) | | 622FT (Tapped) | | |
|---------|--------|-------------------|----------------|----------------|---------|----------------|
| Size | Part # | List \$ | Ship Wt. (lbs) | Part # | List \$ | Ship Wt. (lbs) |
| 1/2" | 781047 | 15.50 | 0.5 | 781244 | 15.50 | 0.5 |
| 3/4" | 781048 | 18.00 | 1 | 781053 | 20.70 | 1 |
| 1" | 781049 | 36.10 | 2 | 781054 | 38.60 | 2 |
| 1 1/4" | 781050 | 48.90 | 3 | 781055 | 56.60 | 3 |
| 1 1/2" | 781051 | 69.60 | 4 | 781056 | 69.60 | 4 |
| 2" | 781052 | 90.10 | 6 | 781057 | 108.10 | 6 |

Union End Full Port Ball Valve

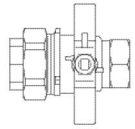

Model 622UF
Model 622UFT (Tapped)

| Size | 622UF (Non Tapped) | | | 622UFT (Tapped) | | |
|--------|--------------------|---------|----------------|-----------------|---------|----------------|
| Size | Part # | List \$ | Ship Wt. (lbs) | Part # | List \$ | Ship Wt. (lbs) |
| 1/2" | 781287 | 18.00 | 1 | 781293 | 20.70 | 1 |
| 3/4" | 781288 | 25.70 | 1.5 | 781294 | 38.60 | 1.5 |
| 1" | 781289 | 41.10 | 2.5 | 781295 | 51.60 | 2.5 |
| 1 1/4" | 781290 | 69.60 | 3.5 | 781296 | 77.30 | 3.5 |
| 1 1/2" | 781291 | 100.40 | 4.5 | 781297 | 108.10 | 4.5 |
| 2" | 781292 | 131.40 | 6.5 | 781298 | 157.00 | 6.5 |

Full Port Test Cock

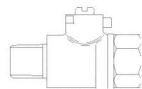

| TC1 | Full Port Test Cock | | |
|---------------|---------------------|---------|----------------|
| Size | Part # | List \$ | Ship Wt. (lbs) |
| 1/8 M x 1/4 F | 781074 | 25.70 | 2 |
| 1/4 M x 1/4 F | 781075 | 25.70 | 2 |

FEBCO BACKFLOW PREVENTION – ACCESSORIES LIST PRICES

Air Gap Drains

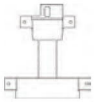

Model 601 Plastic

| Air Gap Drains | | Model 601 For MasterSeries Models 860/860U | | |
|--------------------|--------|--|----------------|--|
| Size | Part # | List \$ | Ship Wt. (lbs) | |
| 1/2", 3/4", 1" | 905358 | 51.60 | 2.5 | |
| 1 1/4", 1 1/2", 2" | 905359 | 63.90 | 2.5 | |

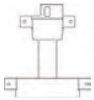

Model 601 Metal

| Air Gap Drains | | Model 601 For MasterSeries Models 860/860U | | |
|--------------------|--------|--|----------------|--|
| Size | Part # | List \$ | Ship Wt. (lbs) | |
| 1/2", 3/4", 1" | 905532 | 55.60 | 3 | |
| 1 1/4", 1 1/2", 2" | 905533 | 67.00 | 3 | |



Model 601

| Air Gap Drains | | Model 601 For MasterSeries Models 860/880V/880 | | |
|----------------|--------|--|----------------|--|
| Size | Part # | List \$ | Ship Wt. (lbs) | |
| 2 1/2" - 10" | 905213 | 164.80 | 3 | |

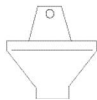

Model AGD-Y Plastic

| Air Gap Drains | | Model AGD-Y Models 825Y/825YA | | |
|----------------|--------|-------------------------------|----------------|--|
| Size | Part # | List \$ | Ship Wt. (lbs) | |
| 3/4" - 2" | 905082 | 51.60 | 3 | |

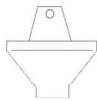

Model AGD-Y Metal

| Air Gap Drains | | Model AGD-Y Models 825Y/825YA | | |
|----------------|--------|-------------------------------|----------------|--|
| Size | Part # | List \$ | Ship Wt. (lbs) | |
| 3/4" - 2" | 905531 | 67.00 | 3 | |

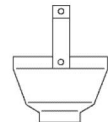

Model AGD-L

| Air Gap Drains | | Model AGD-L Models 825YD/826YD | | |
|----------------|--------|--------------------------------|----------------|--|
| Size | Part # | List \$ | Ship Wt. (lbs) | |
| 2 1/2" - 10" | 905083 | 164.80 | 3 | |

Model 800 By-Pass Kit

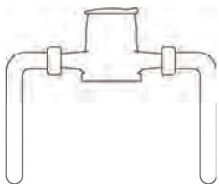

| By-Pass Kit | | Less Meter | | |
|-------------|--------|------------|----------------|--|
| Size | Part # | List \$ | Ship Wt. (lbs) | |
| 3/4" | 905140 | 618.00 | 22 | |

Backflow Prevention Assembly Test Kit

| TK845-5 | | Backflow Prevention Test Kit | | |
|---------|---------|------------------------------|----------------|--|
| Size | Part # | List \$ | Ship Wt. (lbs) | |
| All | TK845-5 | 2,405.00 | 12 | |

FEBCO BACKFLOW PREVENTION – ACCESSORIES LIST PRICES

Strainers (2½" - 10")

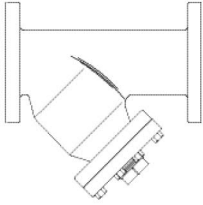

| 758A | Cast Iron Epoxy Coated Flanged "Y" Strainer | | |
|------|---|----------|----------------|
| Size | Part # | List \$ | Ship Wt. (lbs) |
| 2½" | 4325 | 398.70 | 32 |
| 3" | 4326 | 439.40 | 41 |
| 4" | 4327 | 669.30 | 71 |
| 6" | 4328 | 1,238.50 | 150 |
| 8" | 4329 | 2,610.40 | 269 |
| 10" | 4330 | 4,266.10 | 389 |

Strainers (½" - 2")

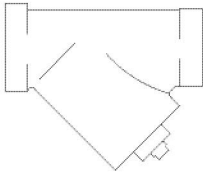

| 650A | Bronze "Y" Strainer | | |
|------|---------------------|---------|----------------|
| Size | Part # | List \$ | Ship Wt. (lbs) |
| ½" | 4303 | 56.60 | 1 |
| ¾" | 4304 | 82.50 | 1 |
| 1" | 4305 | 113.40 | 2 |
| 1¼" | 4306 | 190.60 | 2 |
| 1½" | 4307 | 247.30 | 4 |
| 2" | 4308 | 321.40 | 5 |

FEBCO BACKFLOW PREVENTION – ACCESSORIES LIST PRICES

FREIGHT TERMS:

All shipments are F.O.B. shipping point. Shipments from the factory of less than 500 lbs or \$3,500.00 net are F.O.B. factory. Factory shipments over 500 lbs, \$5,000.00 list or \$3,500.00 net will be prepaid and allowed within Canada when made at the lowest motor carrier transportation rate. Short-shipments and/or damaged goods must be reported within 72 hours.

PAYMENT TERMS:

Invoices are due and payable 30 days from the date of invoice. A 2% cash discount is allowed on net amount of invoice if paid on or before the 10th of the following month. Invoices dated on or after the 25th will be considered as dated the first of the next month.

STOCKING WHOLESALE MINIMUM CHARGE:

A minimum billing charge of \$75.00 applies to shipments F.O.B. factory. Stocking Wholesaler Customers are encouraged to order sufficient material to avoid this charge which is necessitated by increased costs of processing small orders.

SPECIAL PRODUCTS:

Orders for special or modified products are non-cancellable and non-returnable.

LIMITED WARRANTY:

WATTS Industries Canada Inc. warrants each product against defects in material and workmanship for a period of one year from the date of original shipment. In the event of such defects within the warranty period, the Company will, at its option, replace or recondition the product without charge. This shall constitute the exclusive remedy for breach of warranty, and the Company shall not be responsible for any incidental or consequential damages, including, without limitation, damages or

other costs resulting from labor charges, delays, vandalism, negligence, fouling caused by foreign material, damage from adverse water conditions, chemicals, or any other circumstances over which the Company has no control. This warranty shall be invalidated by any abuse, misuse, misapplication or improper installation of the product.

THE COMPANY MAKES NO OTHER WARRANTIES EXPRESS OR IMPLIED EXCEPT AS PROVIDED IN THIS LIMITED WARRANTY.

RETURNED GOODS RESTOCKING CHARGE:

No material shall be returned without authorization. When credit is issued it will be at the price charged, or prevailing price if lower, less handling charges based on costs of reconditioning, boxing, etc. However, a minimum 25% handling charge will apply. A minimum handling charge of \$35.00 is applied whenever the 25% handling deduction does not total \$35.00. Products which are obsolete or made to special order are not returnable.

NOTE:

Prices and terms are subject to change without notice and supersede all previous quotations. The right is reserved to change or modify product design or construction without prior notice and without incurring any obligation to make such changes and modifications on products previously or subsequently sold.

WATTS Industries Canada Inc. reserves the right to modify or change product design or construction without prior notice and without incurring any obligation to make similar changes and modifications to products previously or subsequently sold.

See your WATTS representative for any clarification.



WATTS INDUSTRIES (CANADA) INC.

Canadian Manufacturing and Sales Offices

5435 North Service Road

Burlington, ON

L7L 5H7

Phone: 905-332-4090 Fax: 905-332-7068

www.wattscanada.ca

Toll Free Customer Service: 1-888-208-8927

EXHIBIT "H"

Letter of Support

We, name of organization, support the efforts of BIA Hawaii to remove Section 3 (the Sunset provision) of Act 83, SLH 2012. Removal of the sunset provision in this Act would prohibit the Counties from requiring the installation or retrofitting of automatic fire sprinklers or an automatic fire sprinkler system in most new construction of one or two family residential dwellings, which is currently mandated in the International Residential Code (IRC).

We understand and respect the position of the Fire Fighters in our community and remain committed to preventing loss of life and property through financially sensible building codes and ongoing community education.

At the same time, we in Hawaii are concerned about the dramatic increase in housing prices, especially for our first time home buyers and families. Adding the cost of a new automatic fire sprinkler system and required upgrades to water meters will add to the already high prices of housing in Hawaii.

We firmly believe that there are more cost effective methods of addressing the concerns raised by the fire protection organizations. These methods will not only protect fire fighters and homeowners but will **NOT** significantly increase the price of a new home in Hawaii.

As such, we are in full support of the proposed amendment to Act 83, SLH 2012 to delete the sunset provision of the bill.

Sincerely,

Name of Organization

Subject: Testimony in opposition to HB1384

I am an Architect and community volunteer on the State Building Code Council (SBCC) Green Code Investigative Committee. I believe that creating a blanket exception for residential/agricultural fire sprinklers is not good policy. While I do appreciate the concern about how sprinkler systems impact construction cost, I believe that the benefits of fire sprinklers far outweigh the up-front costs. Studies have shown that the majority of deaths from fire come from single-family house fires and the effectiveness of fire sprinkler systems which often cover multi-family residences is well documented and accepted part of the commercial building code.

Through my volunteer work on the SBCC, I am impressed by the dedication of the appointed members of this body and respect their efforts and openness to community input. I believe any amendments to the building code should come through this body as it is composed of professionals who deal with the effects of building code regulation daily and whose job it is to enforce and maintain the public safety components of the code.

It is held in general practice that local amendments to the building code should not make the code less-safe and that equivalent standards should replace deleted components of the code. HB1384, in its current wording restricts application of fire sprinklers to specific building types and sets a dangerous precedent in that it provides no alternate compliance path to provide an equivalently safe building.

In closing, I urge the committee to defer passage of HB1384 and utilize the SBCC as the expert body to provide amendment recommendations to the building code.

Respectfully submitted,

Brent I. Tokita, AIA

932 Puu Kula Dr.

Pearl City, HI 96782

TESTIMONY OF STEVE BUNTING

A resident of Honolulu

BEFORE THE
HOUSE COMMITTEE ON HOUSING

H.B. 1384
RELATING TO FIRE SPRINKLERS

2:00 PM
FEBRUARY 24th, 2017

Good afternoon Chairman Nishimoto, Vice Chair San Buenaventura and members of this committee. I'm here today to speak in opposition to House Bill 1384.

Since the 1973 publication of "America Burning" by the National Commission on Fire Prevention and Control, the death rate due to fire has been reduced by almost half. However, one statistic that remains constant is that 80% of fire deaths occur in the home¹.

One recommendation listed in America Burning was that "*the Proposed U.S. Fire Administration support the development of the necessary technology for improved automatic extinguishing systems that would find ready acceptance by Americans in all kinds of dwelling units*".

Fire Services in the United States responded and developed regulations that would allow for the inexpensive installation of fire sprinkler systems in single-family dwellings. In 1975, the National Fire Protection Association (NFPA) published the first edition of "Standard 13D", *The Installation of Sprinkler Systems in One- and Two-Family Dwellings and Manufactured Homes*.

With NFPA 13D, the focus was changed to protecting the occupants of a dwelling by requiring "quick response, extended coverage" sprinkler heads and a unique, low cost water distribution system.

With the new design standard in hand, one that permitted the installation of extremely less expensive extinguishing systems, the Nation's fire officials began to seek changes in the building codes which would require fire sprinklers in all residential dwellings.

Pushback from the Nation's homebuilders was immediate. The homebuilders made many false claims about residential sprinkler systems including the cost of installation, water damage from leaks, residential sprinkler systems don't save property and the efficacy of smoke alarms.

Substitution of smoke alarms for extinguishing systems is hampered by two problems; maintenance and reliability. 21% of fire deaths in the United States occurred in homes that had smoke alarms that DID NOT operate. And 40% of all fire deaths occur in homes WITH an operating smoke alarm². Smoke alarms are

¹ In 1973, the President Nixon's National Commission on Fire Prevention and Control conducted a comprehensive study of the growing fire problem in the United States. At the conclusion of the Commission's work, they published the seminal fire prevention document, "America Burning".

² NFPA Smoke Alarm Fact Sheet: Reported home fire death by smoke alarm performance, 2009-2013.

simply not producing the results once hoped for by the fire service and its irresponsible of the homebuilders to continually overstate their effectiveness.

The Building Industry Association's (BIA) claim that a residential fire sprinkler system would "cost upwards of \$30,000 to \$40,000" for a new home in Hawaii, is misleading. In 2008, when the International Code Council adopted the sprinkler requirement for dwellings, the NFPA estimated that the cost to install fire sprinklers in a new dwelling was \$1.60 per square foot. This was supported by empirical data submitted to the Code Body, which indicated that Habitat for Humanity was installing systems in their homes for \$1.50 per square foot.

In 2013, the estimate for an average installation dropped to \$1.35 per square foot. The chart below is NFPA's representation of costs for those two years:

| | 2008 | 2013 |
|---------|-----------------------|-----------------------|
| | \$/ Sprinklered sq ft | \$/ Sprinklered sq ft |
| Mean | \$1.61 | \$1.35 |
| Median | \$1.42 | \$1.22 |
| Minimum | \$0.38 | \$0.81 |
| Maximum | \$3.66 | \$2.47 |

The 2013 cost study included 17 diverse communities across the United States³. Assuming the highest rate found in the study, \$2.47 per square foot, the cost of a sprinkler system in a 2,000 square foot home is \$4,940.00. The cost for the same 2,000 square foot home using the average rate of \$1.35 is \$2,700.00.

The cost cited by the Hawaii BIA is derived from the outrageously high cost to install or upgrade a water meter in Hawaii, Kauai and Maui Counties. A one inch water meter that costs less than \$250.00 to purchase new, costs \$2,300 to install in Honolulu. However, the cost to install the same meter in our other counties is⁴:

- Hawaii County; \$13,800.00
- Maui County; \$15,700.00
- Kauai County; \$26,400.00

Legislation focused on this disparity seems called for.

³ The variation in costs included such variables as extent of coverage, piping material, water source, permit and inspection fees, system design, custom versus tract homes, foundation type, and a variation in sprinkler regulations.

⁴ 2013 State Building Code Council's report on residential sprinkler installations.

Another myth promulgated by the homebuilders is that residential fire sprinklers don't save property. While it's true that the focus of residential sprinkler systems is to save the occupants in the fire's "room of origin", there is plenty of evidence indicating that the systems are effective enough to also contain the fire to the room of origin, or even extinguish the fire. Because of this, the adoption of the residential sprinkler regulations in California came with a valuable benefit to builders and home owners; homes constructed with a residential sprinkler system were allowed to reduce the width of their side yard setbacks and build walls with unprotected openings as close as three feet from a property line. Thereby, increasing the total buildable space on a lot.

Despite statements expressed in the 2013 State Building Code Council's report on residential sprinkler installations, that *"Fire sprinklers have not been proven to enhance the safety of occupants"* and *"...data that suggests that the installation or retrofitting of automatic sprinklers will significantly improve the fire safety of homes does not exist"*, a 15 year study of residential sprinklers in Prince George's County Maryland, demonstrates otherwise:

- During the study period between 1997 and 2007, there were 13,494 single-family and townhouse fires.
- There were 101 deaths and 328 injuries in unsprinklered single-family homes or townhouses;
- There were no deaths and 6 injuries in the fires that occurred in 245 sprinklered single-family homes and townhouses. (There were 445 persons present at the time of the fires.)
- Average per incident property loss in an unsprinklered single family home or town house was \$10,000 and \$50,000 if there was a death.
- Average per incident property loss in a sprinklered single family home or townhouse was \$5,000.

Long-term studies conducted in Bucks County, Pennsylvania and Scottsdale, Arizona showed similar results. In all three studies, there were no deaths in sprinklered single-family homes or townhouses and property losses were greatly reduced.

I hope you'll honor House Resolution 47 of the 2011 legislative session by voting against this bill and supporting residential fire sprinklers in Hawaii⁵. I'll be happy to answer any questions you may have.

⁵ "BE IT RESOLVED by the House of Representatives of the Twenty-sixth Legislature of the State of Hawaii, Regular Session of 2011, that the State Building Code Council is requested to adopt the requirement that automatic fire sprinklers be installed when constructing new one- and two-family dwellings in compliance with the latest edition of nationally-recognized safety codes."

LATE

JUDtestimony

From: Michael Lum <mlum@mlpacific.com>
Sent: Thursday, February 23, 2017 11:42 PM
To: JUDtestimony
Subject: Support for H.B. 1384 H.D. 2 to Keep Sprinklers Optional

Dear Chair Nishimoto,

Dear Chair Nishimoto and members of the Committee,

I am in support of H.B. 1384 H.D. 2, which would keep residential fire sprinklers optional by extending the sunset date by a certain amount of time. I would strongly prefer the original version of this bill, which completely removes the sunset date. Or event the H.D. 1 version, which extends the sunset by 10 years.

I strongly support keeping residential fire sprinklers optional because:

- The cost to a homeowner on Oahu could be about \$35,000 for a system to be designed and installed, and much more on the neighbor islands. With median home prices at \$740,000, adding any more amount of money will easily prevent a family from getting into a home of their own. And, at these prices, a homeowner should be able to determine for themselves their financial situation and what's best for their own family.
- We have a Statewide housing crisis, with over 65,000 new homes needed in Hawaii through 2025. 25,000 of those new homes are needed on Oahu alone. We should be focused on a ffordability of homes, especially since new homes are built much safer than ever before with better technology and fire-retardant materials.
- There are more cost-effective ways to keep your home safe from fires. Kitchen fires are the number one cause of h ome fires, and a homeowner can purchase suppression canisters to place over their stove that will activate when there are flames. Improved technology have brought us sensors that detect when there hasn't been any motion next to an active stovetop and automatically shuts off your stove.
- Sprinkler systems run the risk of water leaks, leading to mold and other damage to your home, which is probably your biggest asset.
- Education and prevention are key to keeping occupants and their home safe.

Thank you for the opportunity to express my support.

Sincerely,

Michael Lum
1302 Kaeleku St
Honolulu, HI 96825
mlum@mlpacific.com

LATE

JUDtestimony

From: paul vierling <paulv@hawaiiigs.com>
Sent: Thursday, February 23, 2017 9:21 PM
To: JUDtestimony
Subject: Support for H.B. 1384 H.D. 2 to Keep Sprinklers Optional

Dear Chair Nishimoto,

Dear Chair Nishimoto and members of the Committee,

I am in support of H.B. 1384 H.D. 2, which would keep residential fire sprinklers optional by extending the sunset date by a certain amount of time. I would strongly prefer the original version of this bill, which completely removes the sunset date. Or event the H.D. 1 version, which extends the sunset by 10 years.

I strongly support keeping residential fire sprinklers optional because:

- The cost to a homeowner on Oahu could be about \$35,000 for a system to be designed and installed, and much more on the neighbor islands. With median home prices at \$740,000, adding any more amount of money will easily prevent a family from getting into a home of their own. And, at these prices, a homeowner should be able to determine for themselves their financial situation and what's best for their own family.
- We have a Statewide housing crisis, with over 65,000 new homes needed in Hawaii through 2025. 25,000 of those new homes are needed on Oahu alone. We should be focused on affordability of homes, especially since new homes are built much safer than ever before with better technology and fire-retardant materials.
- There are more cost-effective ways to keep your home safe from fires. Kitchen fires are the number one cause of home fires, and a homeowner can purchase suppression canisters to place over their stove that will activate when there are flames. Improved technology have brought us sensors that detect when there hasn't been any motion next to an active stovetop and automatically shuts off your stove.
- Sprinkler systems run the risk of water leaks, leading to mold and other damage to your home, which is probably your biggest asset.
- Education and prevention are key to keeping occupants and their home safe.

Thank you for the opportunity to express my support.

Sincerely,

paul vierling
949 Akepo Ln
Honolulu, HI 96817
paulv@hawaiiigs.com

LATE

JUDtestimony

From: Kimo Pierce <Kimo@HawaiiPlumbingGroup.com>
Sent: Thursday, February 23, 2017 8:13 PM
To: JUDtestimony
Subject: Support for H.B. 1384 H.D. 2 to Keep Sprinklers Optional

Dear Chair Nishimoto,

Dear Chair Nishimoto and members of the Committee,

I am in support of H.B. 1384 H.D. 2, which would keep residential fire sprinklers optional by extending the sunset date by a certain amount of time. I would strongly prefer the original version of this bill, which completely removes the sunset date. Or event the H.D. 1 version, which extends the sunset by 10 years.

I strongly support keeping residential fire sprinklers optional because:

- The cost to a homeowner on Oahu could be about \$35,000 for a system to be designed and installed, and much more on the neighbor islands. With median home prices at \$740,000, adding any more amount of money will easily prevent a family from getting into a home of their own. And, at these prices, a homeowner should be able to determine for themselves their financial situation and what's best for their own family.
- We have a Statewide housing crisis, with over 65,000 new homes needed in Hawaii through 2025. 25,000 of those new homes are needed on Oahu alone. We should be focused on affordability of homes, especially since new homes are built much safer than ever before with better technology and fire-retardant materials.
- There are more cost-effective ways to keep your home safe from fires. Kitchen fires are the number one cause of home fires, and a homeowner can purchase suppression canisters to place over their stove that will activate when there are flames. Improved technology have brought us sensors that detect when there hasn't been any motion next to an active stovetop and automatically shuts off your stove.
- Sprinkler systems run the risk of water leaks, leading to mold and other damage to your home, which is probably your biggest asset.
- Education and prevention are key to keeping occupants and their home safe.

Thank you for the opportunity to express my support.

Sincerely,

Kimo Pierce
1177 Queen St
Honolulu, HI 96814
Kimo@HawaiiPlumbingGroup.com

LATE

JUDtestimony

From: Anthony Paresa <nuulolo@mac.com>
Sent: Thursday, February 23, 2017 11:03 PM
To: JUDtestimony
Subject: Support for H.B. 1384 H.D. 2 to Keep Sprinklers Optional

Dear Chair Nishimoto,

Dear Chair Nishimoto and members of the Committee,

I am in support of H.B. 1384 H.D. 2, which would keep residential fire sprinklers optional by extending the sunset date by a certain amount of time. I would strongly prefer the original version of this bill, which completely removes the sunset date. Or event the H.D. 1 version, which extends the sunset by 10 years.

I strongly support keeping residential fire sprinklers optional because:

- The cost to a homeowner on Oahu could be about \$35,000 for a system to be designed and installed, and much more on the neighbor islands. With median home prices at \$740,000, adding any more amount of money will easily prevent a family from getting into a home of their own. And, at these prices, a homeowner should be able to determine for themselves their financial situation and what's best for their own family.
- We have a Statewide housing crisis, with over 65,000 new homes needed in Hawaii through 2025. 25,000 of those new homes are needed on Oahu alone. We should be focused on affordability of homes, especially since new homes are built much safer than ever before with better technology and fire-retardant materials.
- There are more cost-effective ways to keep your home safe from fires. Kitchen fires are the number one cause of home fires, and a homeowner can purchase suppression canisters to place over their stove that will activate when there are flames. Improved technology have brought us sensors that detect when there hasn't been any motion next to an active stovetop and automatically shuts off your stove.
- Sprinkler systems run the risk of water leaks, leading to mold and other damage to your home, which is probably your biggest asset.
- Education and prevention are key to keeping occupants and their home safe.

Thank you for the opportunity to express my support.

Sincerely,

Anthony Paresa
256 Kalalau St
Honolulu, HI 96825
nuulolo@mac.com

LATE

JUDtestimony

From: Tam Reeve <rangerreeve@gmail.com>
Sent: Thursday, February 23, 2017 8:17 PM
To: JUDtestimony
Subject: Support for H.B. 1384 H.D. 2 to Keep Sprinklers Optional

Dear Chair Nishimoto,

Dear Chair Nishimoto and members of the Committee,

I am in support of H.B. 1384 H.D. 2, which would keep residential fire sprinklers optional by extending the sunset date by a certain amount of time. I would strongly prefer the original version of this bill, which completely removes the sunset date. Or event the H.D. 1 version, which extends the sunset by 10 years.

I strongly support keeping residential fire sprinklers optional because:

- The cost to a homeowner on Oahu could be about \$35,000 for a system to be designed and installed, and much more on the neighbor islands. With median home prices at \$740,000, adding any more amount of money will easily prevent a family from getting into a home of their own. And, at these prices, a homeowner should be able to determine for themselves their financial situation and what's best for their own family.
- We have a Statewide housing crisis, with over 65,000 new homes needed in Hawaii through 2025. 25,000 of those new homes are needed on Oahu alone. We should be focused on affordability of homes, especially since new homes are built much safer than ever before with better technology and fire-retardant materials.
- There are more cost-effective ways to keep your home safe from fires. Kitchen fires are the number one cause of home fires, and a homeowner can purchase suppression canisters to place over their stove that will activate when there are flames. Improved technology have brought us sensors that detect when there hasn't been any motion next to an active stovetop and automatically shuts off your stove.
- Sprinkler systems run the risk of water leaks, leading to mold and other damage to your home, which is probably your biggest asset.
- Education and prevention are key to keeping occupants and their home safe.

Thank you for the opportunity to express my support.

Sincerely,

Tam Reeve
5498 Bittern Ave
Ewa Beach, HI 96706
rangerreeve@gmail.com

LATE

JUDtestimony

From: Craig Washofsky <craigw@servco.com>
Sent: Thursday, February 23, 2017 9:21 PM
To: JUDtestimony
Subject: Support for H.B. 1384 H.D. 2 to Keep Sprinklers Optional

Dear Chair Nishimoto,

Dear Chair Nishimoto and members of the Committee,

I am in support of H.B. 1384 H.D. 2, which would keep residential fire sprinklers optional by extending the sunset date by a certain amount of time. I would strongly prefer the original version of this bill, which completely removes the sunset date. Or event the H.D. 1 version, which extends the sunset by 10 years.

I strongly support keeping residential fire sprinklers optional because:

- The cost to a homeowner on Oahu could be about \$35,000 for a system to be designed and installed, and much more on the neighbor islands. With median home prices at \$740,000, adding any more amount of money will easily prevent a family from getting into a home of their own. And, at these prices, a homeowner should be able to determine for themselves their financial situation and what's best for their own family.
- We have a Statewide housing crisis, with over 65,000 new homes needed in Hawaii through 2025. 25,000 of those new homes are needed on Oahu alone. We should be focused on affordability of homes, especially since new homes are built much safer than ever before with better technology and fire-retardant materials.
- There are more cost-effective ways to keep your home safe from fires. Kitchen fires are the number one cause of home fires, and a homeowner can purchase suppression canisters to place over their stove that will activate when there are flames. Improved technology have brought us sensors that detect when there hasn't been any motion next to an active stovetop and automatically shuts off your stove.
- Sprinkler systems run the risk of water leaks, leading to mold and other damage to your home, which is probably your biggest asset.
- Education and prevention are key to keeping occupants and their home safe.

Thank you for the opportunity to express my support.

Sincerely,

Craig Washofsky
825 Alahaki St
Kailua, HI 96734
craigw@servco.com

JUDtestimony

From: Brian Moore <brian.moore@centralpacificbank.com>
Sent: Friday, February 24, 2017 8:00 AM
To: JUDtestimony
Subject: Support for H.B. 1384 H.D. 2 to Keep Sprinklers Optional

Dear Chair Nishimoto,

Dear Chair Nishimoto and members of the Committee,

I am in support of H.B. 1384 H.D. 2, which would keep residential fire sprinklers optional by extending the sunset date by a certain amount of time. I would strongly prefer the original version of this bill, which completely removes the sunset date. Or event the H.D. 1 version, which extends the sunset by 10 years.

I strongly support keeping residential fire sprinklers optional because:

- The cost to a homeowner on Oahu could be about \$35,000 for a system to be designed and installed, and much more on the neighbor islands. With median home prices at \$740,000, adding any more amount of money will easily prevent a family from getting into a home of their own. And, at these prices, a homeowner should be able to determine for themselves their financial situation and what's best for their own family.
- We have a Statewide housing crisis, with over 65,000 new homes needed in Hawaii through 2025. 25,000 of those new homes are needed on Oahu alone. We should be focused on affordability of homes, especially since new homes are built much safer than ever before with better technology and fire-retardant materials.
- There are more cost-effective ways to keep your home safe from fires. Kitchen fires are the number one cause of home fires, and a homeowner can purchase suppression canisters to place over their stove that will activate when there are flames. Improved technology have brought us sensors that detect when there hasn't been any motion next to an active stovetop and automatically shuts off your stove.
- Sprinkler systems run the risk of water leaks, leading to mold and other damage to your home, which is probably your biggest asset.
- Education and prevention are key to keeping occupants and their home safe.

Thank you for the opportunity to express my support.

Sincerely,

Brian Moore
1487 Hiiikala Pl # 7
Honolulu, HI 96816
brian.moore@centralpacificbank.com

JUDtestimony

From: Timothy Waite <twait@strongtie.com>
Sent: Thursday, February 23, 2017 6:06 PM
To: JUDtestimony
Subject: Support for H.B. 1384 H.D. 2 to Keep Sprinklers Optional

Dear Chair Nishimoto,

Let's not raise the cost of already expensive housing!!

Dear Chair Nishimoto and members of the Committee,

I am in support of H.B. 1384 H.D. 2, which would keep residential fire sprinklers optional by extending the sunset date by a certain amount of time. I would strongly prefer the original version of this bill, which completely removes the sunset date. Or event the H.D. 1 version, which extends the sunset by 10 years.

I strongly support keeping residential fire sprinklers optional because:

- The cost to a homeowner on Oahu could be about \$35,000 for a system to be designed and installed, and much more on the neighbor islands. With median home prices at \$740,000, adding any more amount of money will easily prevent a family from getting into a home of their own. And, at these prices, a homeowner should be able to determine for themselves their financial situation and what's best for their own family.
- We have a Statewide housing crisis, with over 65,000 new homes needed in Hawaii through 2025. 25,000 of those new homes are needed on Oahu alone. We should be focused on affordability of homes, especially since new homes are built much safer than ever before with better technology and fire-retardant materials.
- There are more cost-effective ways to keep you r home safe from fires. Kitchen fires are the number one cause of home fires, and a homeowner can purchase suppression canisters to place over their stove that will activate when there are flames. Improved technology have brought us sensors that detect when there hasn't been any motion next to an active stovetop and automatically shuts off your stove.
- Sprinkler systems run the risk of water leaks, leading to mold and other damage to your home, which is probably your biggest asset.
- Education and prevention are key to keeping occupants and their home safe.

Thank you for the opportunity to express my support.

Sincerely,

Timothy Waite
92-1214 MAKAKILO DR APT 29
KAPOLEI, HI 96707
twait@strongtie.com

JUDtestimony

From: John Cheung <john@ccengineeringhawaii.com>
Sent: Thursday, February 23, 2017 5:42 PM
To: JUDtestimony
Subject: Support for H.B. 1384 H.D. 2 to Keep Sprinklers Optional

Dear Chair Nishimoto,

Dear Chair Nishimoto and members of the Committee,

I am in support of H.B. 1384 H.D. 2, which would keep residential fire sprinklers optional by extending the sunset date by a certain amount of time. I would strongly prefer the original version of this bill, which completely removes the sunset date. Or event the H.D. 1 version, which extends the sunset by 10 years.

I strongly support keeping residential fire sprinklers optional because:

- The cost to a homeowner on Oahu could be about \$35,000 for a system to be designed and installed, and much more on the neighbor islands. With median home prices at \$740,000, adding any more amount of money will easily prevent a family from getting into a home of their own. And, at these prices, a homeowner should be able to determine for themselves their financial situation and what's best for their own family.
- We have a Statewide housing crisis, with over 65,000 new homes needed in Hawaii through 2025. 25,000 of those new homes are needed on Oahu alone. We should be focused on affordability of homes, especially since new homes are built much safer than ever before with better technology and fire-retardant materials.
- There are more cost-effective ways to keep your home safe from fires. Kitchen fires are the number one cause of home fires, and a homeowner can purchase suppression canisters to place over their stove that will activate when there are flames. Improved technology have brought us sensors that detect when there hasn't been any motion next to an active stovetop and automatically shuts off your stove.
- Sprinkler systems run the risk of water leaks, leading to mold and other damage to your home, which is probably your biggest asset.
- Education and prevention are key to keeping occupants and their home safe.

Thank you for the opportunity to express my support.

Sincerely,

John Cheung
45-527 APAPANE ST
KANEEOHE, HI 96744
john@ccengineeringhawaii.com

JUDtestimony

From: Evan Fujimoto <evan@grahambuilders.com>
Sent: Thursday, February 23, 2017 6:00 PM
To: JUDtestimony
Subject: Support for H.B. 1384 H.D. 2 to Keep Sprinklers Optional

Dear Chair Nishimoto,

Dear Chair Nishimoto and members of the Committee,

I am in support of H.B. 1384 H.D. 2, which would keep residential fire sprinklers optional by extending the sunset date by a certain amount of time. I would strongly prefer the original version of this bill, which completely removes the sunset date. Or event the H.D. 1 version, which extends the sunset by 10 years.

I strongly support keeping residential fire sprinklers optional because:

- The cost to a homeowner on Oahu could be about \$35,000 for a system to be designed and installed, and much more on the neighbor islands. With median home prices at \$740,000, adding any more amount of money will easily prevent a family from getting into a home of their own. And, at these prices, a homeowner should be able to determine for themselves their financial situation and what's best for their own family.
- We have a Statewide housing crisis, with over 65,000 new homes needed in Hawaii through 2025. 25,000 of those new homes are needed on Oahu alone. We should be focused on affordability of homes, especially since new homes are built much safer than ever before with better technology and fire-retardant materials.
- There are more cost-effective ways to keep your home safe from fires. Kitchen fires are the number one cause of home fires, and a homeowner can purchase suppression canisters to place over their stove that will activate when there are flames. Improved technology have brought us sensors that detect when there hasn't been any motion next to an active stovetop and automatically shuts off your stove.
- Sprinkler systems run the risk of water leaks, leading to mold and other damage to your home, which is probably your biggest asset.
- Education and prevention are key to keeping occupants and their home safe.

Thank you for the opportunity to express my support.

Sincerely,

Evan Fujimoto
5616 Haleola St
Honolulu, HI 96821
evan@grahambuilders.com

LATE

JUDtestimony

From: Mr. & Mrs. Gary Okimoto <koapens@hawaii.rr.com>
Sent: Thursday, February 23, 2017 5:43 PM
To: JUDtestimony
Subject: Support for H.B. 1384 H.D. 2 to Keep Sprinklers Optional

Dear Chair Nishimoto,

Dear Chair Nishimoto and members of the Committee,

I am in support of H.B. 1384 H.D. 2, which would keep residential fire sprinklers optional by extending the sunset date by a certain amount of time. I would strongly prefer the original version of this bill, which completely removes the sunset date. Or event the H.D. 1 version, which extends the sunset by 10 years.

I strongly support keeping residential fire sprinklers optional because:

- The cost to a homeowner on Oahu could be about \$35,000 for a system to be designed and installed, and much more on the neighbor islands. With median home prices at \$740,000, adding any more amount of money will easily prevent a family from getting into a home of their own. And, at these prices, a homeowner should be able to determine for themselves their financial situation and what's best for their own family.
- We have a Statewide housing crisis, with over 65,000 new homes needed in Hawaii through 2025. 25,000 of those new homes are needed on Oahu alone. We should be focused on affordability of homes, especially since new homes are built much safer than ever before with better technology and fire-retardant materials.
- There are more cost-effective ways to keep your home safe from fires. Kitchen fires are the number one cause of home fires, and a homeowner can purchase suppression canisters to place over their stove that will activate when there are flames. Improved technology have brought us sensors that detect when there hasn't been any motion next to an active stovetop and automatically shuts off your stove.
- Sprinkler systems run the risk of water leaks, leading to mold and other damage to your home, which is probably your biggest asset.
- Education and prevention are key to keeping occupants and their home safe.

Thank you for the opportunity to express my support.

Sincerely,

Gary Okimoto
92-1328 Punawainui St
Kapolei, HI 96707
koapens@hawaii.rr.com

From: Debra Luning <DebbieL@GentryHawaii.com>
Sent: Friday, February 24, 2017 9:04 AM
To: JUDtestimony
Subject: Support for H.B. 1384 H.D. 2 to Keep Sprinklers Optional

Dear Chair Nishimoto,

Dear Chair Nishimoto and members of the Committee,

I am in support of H.B. 1384 H.D. 2, which would keep residential fire sprinklers optional by extending the sunset date by a certain amount of time. I would strongly prefer the original version of this bill, which completely removes the sunset date. Or event the H.D. 1 version, which extends the sunset by 10 years.

I strongly support keeping residential fire sprinklers optional because:

- The cost to a homeowner on Oahu could be about \$35,000 for a system to be designed and installed, and much more on the neighbor islands. With median home prices at \$740,000, adding any more amount of money will easily prevent a family from getting into a home of their own. And, at these prices, a homeowner should be able to determine for themselves their financial situation and what's best for their own family.
- We have a Statewide housing crisis, with over 65,000 new homes needed in Hawaii through 2025. 25,000 of those new homes are needed on Oahu alone. We should be focused on affordability of homes, especially since new homes are built much safer than ever before with better technology and fire-retardant materials.
- There are more cost-effective ways to keep your home safe from fires. Kitchen fires are the number one cause of home fires, and a homeowner can purchase suppression canisters to place over their stove that will activate when there are flames. Improved technology have brought us sensors that detect when there hasn't been any motion next to an active stovetop and automatically shuts off your stove.
- Sprinkler systems run the risk of water leaks, leading to mold and other damage to your home, which is probably your biggest asset.
- Education and prevention are key to keeping occupants and their home safe.

Thank you for the opportunity to express my support.

Sincerely,

Debra Luning
2825 S King St
Honolulu, HI 96826
DebbieL@GentryHawaii.com

From: [Christopher Cheung](#)
To: [JUDtestimony](#)
Subject: Support for H.B. 1384 H.D. 2 to Keep Sprinklers Optional
Date: Friday, February 24, 2017 8:40:14 AM



Dear Chair Nishimoto,

Fire sprinklers are not necessary. They are not meant to put out the fire or save fire fighters lives. The design is to allow occupants time to escape. Most of Oahu's residential homes are small, you can escape a fire easily through a window. It not necessary to have a \$50K fire sprinkler system in your home. Fire sprinkler requires maintenance which could cost \$1,000 per year. Also a \$5 smoke detector will work just as well. The City's existing infrastructure will not be able to handle fire sprinkler requirements. This will cause the building department to reject new renovations.

Dear Chair Nishimoto and members of the Committee,

I am in support of H.B. 1384 H.D. 2, which would keep residential fire sprinklers optional by extending the sunset date by a certain amount of time. I would strongly prefer the original version of this bill, which completely removes the sunset date. Or event the H.D. 1 version, which extends the sunset by 10 years.

I strongly support keeping residential fire sprinklers optional because:

- The cost to a homeowner on Oahu could be about \$35,000 for a system to be designed and installed, and much more on the neighbor islands. With median home prices at \$740,000, adding any more amount of money will easily prevent a family from getting into a home of their own. And, at these prices, a homeowner should be able to determine for themselves their financial situation and what's best for their own family.
- We have a Statewide housing crisis, with over 65,000 new homes needed in Hawaii through 2025. 25,000 of those new homes are needed on Oahu alone. We should be focused on affordability of homes, especially since new homes are built much safer than ever before with better technology and fire-retardant materials.
- There are more cost-effective ways to keep your home safe from fires. Kitchen fires are the number one cause of home fires, and a homeowner can purchase suppression canisters to place over their stove that will activate when there are flames. Improved technology have brought us sensors that detect when there hasn't been any motion next to an active stovetop and automatically shuts off your stove.
- Sprinkler systems run the risk of water leaks, leading to mold and other damage to your home, which is probably your biggest asset.
- Education and prevention are key to keeping occupants and their home safe.

Thank you for the opportunity to express my support.

Sincerely,

Christopher Cheung
45-574 PAHOLEI ST
KANEEOHE, HI 96744
chris@ccengineeringhawaii.com

From: David Leong <dcr@dcrhawaii.com>
Sent: Friday, February 24, 2017 6:47 AM
To: JUDtestimony
Subject: Support for H.B. 1384 H.D. 2 to Keep Sprinklers Optional

Dear Chair Nishimoto,

Dear Chair Nishimoto and members of the Committee,

I am in support of H.B. 1384 H.D. 2, which would keep residential fire sprinklers optional by extending the sunset date by a certain amount of time. I would strongly prefer the original version of this bill, which completely removes the sunset date. Or event the H.D. 1 version, which extends the sunset by 10 years.

I strongly support keeping residential fire sprinklers optional because:

- The cost to a homeowner on Oahu could be about \$35,000 for a system to be designed and installed, and much more on the neighbor islands. With median home prices at \$740,000, adding any more amount of money will easily prevent a family from getting into a home of their own. And, at these prices, a homeowner should be able to determine for themselves their financial situation and what's best for their own family.
- We have a Statewide housing crisis, with over 65,000 new homes needed in Hawaii through 2025. 25,000 of those new homes are needed on Oahu alone. We should be focused on affordability of homes, especially since new homes are built much safer than ever before with better technology and fire-retardant materials.
- There are more cost-effective ways to keep your home safe from fires. Kitchen fires are the number one cause of home fires, and a homeowner can purchase suppression canisters to place over their stove that will activate when there are flames. Improved technology have brought us sensors that detect when there hasn't been any motion next to an active stovetop and automatically shuts off your stove.
- Sprinkler systems run the risk of water leaks, leading to mold and other damage to your home, which is probably your biggest asset.
- Education and prevention are key to keeping occupants and their home safe.

Thank you for the opportunity to express my support.

Sincerely,

David Leong
1740 Kumakani Loop
Honolulu, HI 96821
dcr@dcrhawaii.com

From: Timothy Waite <twait@strongtie.com>
Sent: Thursday, February 23, 2017 6:06 PM
To: JUDtestimony
Subject: Support for H.B. 1384 H.D. 2 to Keep Sprinklers Optional

Dear Chair Nishimoto,

Let's not raise the cost of already expensive housing!!

Dear Chair Nishimoto and members of the Committee,

I am in support of H.B. 1384 H.D. 2, which would keep residential fire sprinklers optional by extending the sunset date by a certain amount of time. I would strongly prefer the original version of this bill, which completely removes the sunset date. Or event the H.D. 1 version, which extends the sunset by 10 years.

I strongly support keeping residential fire sprinklers optional because:

- The cost to a homeowner on Oahu could be about \$35,000 for a system to be designed and installed, and much more on the neighbor islands. With median home prices at \$740,000, adding any more amount of money will easily prevent a family from getting into a home of their own. And, at these prices, a homeowner should be able to determine for themselves their financial situation and what's best for their own family.
- We have a Statewide housing crisis, with over 65,000 new homes needed in Hawaii through 2025. 25,000 of those new homes are needed on Oahu alone. We should be focused on affordability of homes, especially since ne w homes are built much safer than ever before with better technology and fire-retardant materials.
- There are more cost-effective ways to keep your home safe from fires. Kitchen fires are the number one cause of home fires, and a homeowner can purchase suppression canisters to place over their stove that will activate when there are flames. Improved technology have brought us sensors that detect when there hasn't been any motion next to an active stovetop and automatically shuts off your stove.
- Sprinkler systems run the risk of water leaks, leading to mold and other damage to your home, which is probably your biggest asset.
- Education and prevention are key to keeping occupants and their home safe.

Thank you for the opportunity to express my support.

Sincerely,

Timothy Waite
92-1214 MAKAKILO DR APT 29
KAPOLEI, HI 96707
twait@strongtie.com

From: Jessica Omoto <jesm1@hawaiiantel.net>
Sent: Thursday, February 23, 2017 7:05 PM
To: JUDtestimony
Subject: Support for H.B. 1384 H.D. 2 to Keep Sprinklers Optional

Dear Chair Nishimoto,

Dear Chair Nishimoto and members of the Committee,

I am in support of H.B. 1384 H.D. 2, which would keep residential fire sprinklers optional by extending the sunset date by a certain amount of time. I would strongly prefer the original version of this bill, which completely removes the sunset date. Or event the H.D. 1 version, which extends the sunset by 10 years.

I strongly support keeping residential fire sprinklers optional because:

- The cost to a homeowner on Oahu could be about \$35,000 for a system to be designed and installed, and much more on the neighbor islands. With median home prices at \$740,000, adding any more amount of money will easily prevent a family from getting into a home of their own. And, at these prices, a homeowner should be able to determine for themselves their financial situation and what's best for their own family.
- We have a Statewide housing crisis, with over 65,000 new homes needed in Hawaii through 2025. 25,000 of those new homes are needed on Oahu alone. We should be focused on affordability of homes, especially since new homes are built much safer than ever before with better technology and fire-retardant materials.
- There are more cost-effective ways to keep your home safe from fires. Kitchen fires are the number one cause of home fires, and a homeowner can purchase suppression canisters to place over their stove that will activate when there are flames. Improved technology have brought us sensors that detect when there hasn't been any motion next to an active stovetop and automatically shuts off your stove.
- Sprinkler systems run the risk of water leaks, leading to mold and other damage to your home, which is probably your biggest asset.
- Education and prevention are key to keeping occupants and their home safe.

Thank you for the opportunity to express my support.

Sincerely,

Jessica Omoto
98-402 KOAUKA LOOP APT 2215
AIEA, HI 96701
jesm1@hawaiiantel.net

LATE

JUDtestimony

From: Sharon Schneider <stys808@gmail.com>
Sent: Thursday, February 23, 2017 9:29 PM
To: JUDtestimony
Subject: Support for H.B. 1384 H.D. 2 to Keep Sprinklers Optional

Dear Chair Nishimoto,

Dear Chair Nishimoto and members of the Committee,

I am in support of H.B. 1384 H.D. 2, which would keep residential fire sprinklers optional by extending the sunset date by a certain amount of time. I would strongly prefer the original version of this bill, which completely removes the sunset date. Or event the H.D. 1 version, which extends the sunset by 10 years.

I strongly support keeping residential fire sprinklers optional because:

- The cost to a homeowner on Oahu could be about \$35,000 for a system to be designed and installed, and much more on the neighbor islands. With median home prices at \$740,000, adding any more amount of money will easily prevent a family from getting into a home of their own. And, at these prices, a homeowner should be able to determine for themselves their financial situation and what's best for their own family.
- We have a Statewide housing crisis, with over 65,000 new homes needed in Hawaii through 2025. 25,000 of those new homes are needed on Oahu alone. We should be focused on affordability of homes, especially since new homes are built much safer than ever before with better technology and fire-retardant materials.
- There are more cost-effective ways to keep your home safe from fires. Kitchen fires are the number one cause of home fires, and a homeowner can purchase suppression canisters to place over their stove that will activate when there are flames. Improved technology have brought us sensors that detect when there hasn't been any motion next to an active stovetop and automatically shuts off your stove.
- Sprinkler systems run the risk of water leaks, leading to mold and other damage to your home, which is probably your biggest asset.
- Education and prevention are key to keeping occupants and their home safe.

Thank you for the opportunity to express my support.

Sincerely,

Sharon Schneider
5042 Maunalani Cir
Honolulu, HI 96816
stys808@gmail.com

From: Dean Asahina <uci@att.net>
Sent: Thursday, February 23, 2017 5:19 PM
To: JUDtestimony
Subject: Support for H.B. 1384 H.D. 2 to Keep Sprinklers Optional

Dear Chair Nishimoto,

Dear Chair Nishimoto and members of the Committee,

I am in support of H.B. 1384 H.D. 2, which would keep residential fire sprinklers optional by extending the sunset date by a certain amount of time. I would strongly prefer the original version of this bill, which completely removes the sunset date. Or event the H.D. 1 version, which extends the sunset by 10 years.

I strongly support keeping residential fire sprinklers optional because:

- The cost to a homeowner on Oahu could be about \$35,000 for a system to be designed and installed, and much more on the neighbor islands. With median home prices at \$740,000, adding any more amount of money will easily prevent a family from getting into a home of their own. And, at these prices, a homeowner should be able to determine for themselves their financial situation and what's best for their own family.
- We have a Statewide housing crisis, with over 65,000 new homes needed in Hawaii through 2025. 25,000 of those new homes are needed on Oahu alone. We should be focused on affordability of homes, especially since new homes are built much safer than ever before with better technology and fire-retardant materials.
- There are more cost-effective ways to keep yo ur home safe from fires. Kitchen fires are the number one cause of home fires, and a homeowner can purchase suppression canisters to place over their stove that will activate when there are flames. Improved technology have brought us sensors that detect when there hasn't been any motion next to an active stovetop and automatically shuts off your stove.
- Sprinkler systems run the risk of water leaks, leading to mold and other damage to your home, which is probably your biggest asset.
- Education and prevention are key to keeping occupants and their home safe.

Thank you for the opportunity to express my support.

Sincerely,

Dean Asahina
3395 Niolopua Dr
Honolulu, HI 96817
uci@att.net

LATE

JUDtestimony

From: Dwight Mitsunaga <dmitsunaga@pacarchitects.com>
Sent: Thursday, February 23, 2017 5:18 PM
To: JUDtestimony
Subject: Support for H.B. 1384 H.D. 2 to Keep Sprinklers Optional

Dear Chair Nishimoto,

Dear Chair Nishimoto and members of the Committee,

I am in support of H.B. 1384 H.D. 2, which would keep residential fire sprinklers optional by extending the sunset date by a certain amount of time. I would strongly prefer the original version of this bill, which completely removes the sunset date. Or event the H.D. 1 version, which extends the sunset by 10 years.

I strongly support keeping residential fire sprinklers optional because:

- The cost to a homeowner on Oahu could be about \$35,000 for a system to be designed and installed, and much more on the neighbor islands. With median home prices at \$740,000, adding any more amount of money will easily prevent a family from getting into a home of their own. And, at these prices, a homeowner should be able to determine for themselves their financial situation and what's best for their own family.
- We have a Statewide housing crisis, with over 65,000 new homes needed in Hawaii through 2025. 25,000 of those new homes are needed on Oahu alone. We should be focused on affordability of homes, especially since new homes are built much safer than ever before with better technology and fire-retardant materials.
- There are more cost-effective ways to keep your home safe from fires. Kitchen fires are the number one cause of home fires, and a homeowner can purchase suppression canisters to place over their stove that will activate when there are flames. Improved technology have brought us sensors that detect when there hasn't been any motion next to an active stovetop and automatically shuts off your stove.
- Sprinkler systems run the risk of water leaks, leading to mold and other damage to your home, which is probably your biggest asset.
- Education and prevention are key to keeping occupants and their home safe.

Thank you for the opportunity to express my support.

Sincerely,

Dwight Mitsunaga
817 Ikena Cir
Honolulu, HI 96821
dmitsunaga@pacarchitects.com

LATE

JUDtestimony

From: Greg Liu <greg@dtchawaii.com>
Sent: Thursday, February 23, 2017 6:40 PM
To: JUDtestimony
Subject: Support for H.B. 1384 H.D. 2 to Keep Sprinklers Optional

Dear Chair Nishimoto,

Dear Chair Nishimoto and members of the Committee,

I am in support of H.B. 1384 H.D. 2, which would keep residential fire sprinklers optional by extending the sunset date by a certain amount of time. I would strongly prefer the original version of this bill, which completely removes the sunset date. Or even the H.D. 1 version, which extends the sunset by 10 years.

I strongly support keeping residential fire sprinklers optional because:

- The cost to a homeowner on Oahu could be about \$35,000 for a system to be designed and installed, and much more on the neighbor islands. With median home prices at \$740,000, adding any more amount of money will easily prevent a family from getting into a home of their own. And, at these prices, a homeowner should be able to determine for themselves their financial situation and what's best for their own family.
- We have a Statewide housing crisis, with over 65,000 new homes needed in Hawaii through 2025. 25,000 of those new homes are needed on Oahu alone. We should be focused on affordability of homes, especially since new homes are built much safer than ever before with better technology and fire-retardant materials.
- There are more cost-effective ways to keep your home safe from fires. Kitchen fires are the number one cause of home fires, and a homeowner can purchase suppression canisters to place over their stove that will activate when there are flames. Improved technology have brought us sensors that detect when there hasn't been any motion next to an active stovetop and automatically shuts off your stove.
- Sprinkler systems run the risk of water leaks, leading to mold and other damage to your home, which is probably your biggest asset.
- Education and prevention are key to keeping occupants and their home safe.

Thank you for the opportunity to express my support.

In my opinion, it is never the government's responsibility or jurisdiction to legislate in the area of an individual's property unless that property is involved with illegal activities. If the State of Hawaii can implement this requirement, then the doors are open wide for them to legislate any other areas of the home. Will the State then be liable for any residential fires if the legislation is faulty in their specific requirements. I know that answer will be "no", so likewise with all due respect, please say "non" to this bill.

Sincerely,

Greg Liu
92-831 MAKAKILO DR
KAPOLEI, HI 96707
greg@dtchawaii.com

From: Greg Sakamoto <greg@scpacific.com>
Sent: Thursday, February 23, 2017 5:20 PM
To: JUDtestimony
Subject: Support for H.B. 1384 H.D. 2 to Keep Sprinklers Optional

Dear Chair Nishimoto,

Dear Chair Nishimoto and members of the Committee,

I am in support of H.B. 1384 H.D. 2, which would keep residential fire sprinklers optional by extending the sunset date by a certain amount of time. I would strongly prefer the original version of this bill, which completely removes the sunset date. Or event the H.D. 1 version, which extends the sunset by 10 years.

I strongly support keeping residential fire sprinklers optional because:

- The cost to a homeowner on Oahu could be about \$35,000 for a system to be designed and installed, and much more on the neighbor islands. With median home prices at \$740,000, adding any more amount of money will easily prevent a family from getting into a home of their own. And, at these prices, a homeowner should be able to determine for themselves their financial situation and what's best for their own family.
- We have a Statewide housing crisis, with over 65,000 new homes needed in Hawaii through 2025. 25,000 of those new homes are needed on Oahu alone. We should be fo cused on affordability of homes, especially since new homes are built much safer than ever before with better technology and fire-retardant materials.
- There are more cost-effective ways to keep your home safe from fires. Kitchen fires are the number one cause of home fires, and a homeowner can purchase suppression canisters to place over their stove that will activate when there are flames. Improved technology have brought us sensors that detect when there hasn't been any motion next to an active stovetop and automatically shuts off your stove.
- Sprinkler systems run the risk of water leaks, leading to mold and other damage to your home, which is probably your biggest asset.
- Education and prevention are key to keeping occupants and their home safe.

Thank you for the opportunity to express my support.

Sincerely,

Greg F Sakamoto
1248 Ala Mahamoe St
Honolulu, HI 96819
greg@scpacific.com

LATE

From: Andrew Lui-Kwan <aluikwan@lghausys.com>
Sent: Thursday, February 23, 2017 5:26 PM
To: JUDtestimony
Subject: Support for H.B. 1384 H.D. 2 to Keep Sprinklers Optional

Dear Chair Nishimoto,

Dear Chair Nishimoto and members of the Committee,

I am in support of H.B. 1384 H.D. 2, which would keep residential fire sprinklers optional by extending the sunset date by a certain amount of time. I would strongly prefer the original version of this bill, which completely removes the sunset date. Or event the H.D. 1 version, which extends the sunset by 10 years.

I strongly support keeping residential fire sprinklers optional because:

- The cost to a homeowner on Oahu could be about \$35,000 for a system to be designed and installed, and much more on the neighbor islands. With median home prices at \$740,000, adding any more amount of money will easily prevent a family from getting into a home of their own. And, at these prices, a homeowner should be able to determine for themselves their financial situation and what's best for their own family.
- We have a Statewide housing crisis, with over 65,000 new homes needed in Hawaii through 2025. 25,000 of those new homes are needed on Oahu alone. We should be focused on affordability of homes, especially since new homes are built much safer than ever before with better technology and fire-retardant materials.
- There are more cost-effective ways to keep your home safe from fires. Kitchen fires are the number one cause of home fires, and a homeowner can purchase suppression canisters to place over their stove that will activate when there are flames. Improved technology have brought us sensors that detect when there hasn't been any motion next to an active stovetop and automatically shuts off your stove.
- Sprinkler systems run the risk of water leaks, leading to mold and other damage to your home, which is probably your biggest asset.
- Education and prevention are key to keeping occupants and their home safe.

Thank you for the opportunity to express my support.

Sincerely,

Andrew Lui-Kwan
91-1089 PUAMAEOLE ST
EWA BEACH, HI 96706
aluikwan@lghausys.com

From: Brian Adachi <bkadachi@bkabuilders.com>
Sent: Thursday, February 23, 2017 5:36 PM
To: JUDtestimony
Subject: Support for H.B. 1384 H.D. 2 to Keep Sprinklers Optional

Dear Chair Nishimoto,

Dear Chair Nishimoto and members of the Committee,

I am in support of H.B. 1384 H.D. 2, which would keep residential fire sprinklers optional by extending the sunset date by a certain amount of time. I would strongly prefer the original version of this bill, which completely removes the sunset date. Or event the H.D. 1 version, which extends the sunset by 10 years.

I strongly support keeping residential fire sprinklers optional because:

- The cost to a homeowner on Oahu could be about \$35,000 for a system to be designed and installed, and much more on the neighbor islands. With median home prices at \$740,000, adding any more amount of money will easily prevent a family from getting into a home of their own. And, at these prices, a homeowner should be able to determine for themselves their financial situation and what's best for their own family.
- We have a Statewide housing crisis, with over 65,000 new homes needed in Hawaii through 2025. 25,000 of those new homes are needed on Oahu alone. We should be focused on affordability of homes, especially since new homes are built much safer than ever before with better technology and fire-retardant materials.
- There are more cost-effective ways to keep your home safe from fires. Kitchen fires are the number one cause of home fires, and a homeowner can purchase suppression canisters to place over their stove that will activate when there are flames. Improved technology have brought us sensors that detect when there hasn't been any motion next to an active stovetop and automatically shuts off your stove.
- Sprinkler systems run the risk of water leaks, leading to mold and other damage to your home, which is probably your biggest asset.
- Education and prevention are key to keeping occupants and their home safe.

Thank you for the opportunity to express my support.

Sincerely,

Brian Adachi
6478 Hawaii Kai Dr
Honolulu, HI 96825
bkadachi@bkabuilders.com



From: Curt Kiriu <curtk@hawaii.rr.com>
Sent: Thursday, February 23, 2017 5:36 PM
To: JUDtestimony
Subject: Support for H.B. 1384 H.D. 2 to Keep Sprinklers Optional

Dear Chair Nishimoto,

Dear Chair Nishimoto and members of the Committee,

I am in support of H.B. 1384 H.D. 2, which would keep residential fire sprinklers optional by extending the sunset date by a certain amount of time. I would strongly prefer the original version of this bill, which completely removes the sunset date. Or event the H.D. 1 version, which extends the sunset by 10 years.

I strongly support keeping residential fire sprinklers optional because:

- The cost to a homeowner on Oahu could be about \$35,000 for a system to be designed and installed, and much more on the neighbor islands. With median home prices at \$740,000, adding any more amount of money will easily prevent a family from getting into a home of their own. And, at these prices, a homeowner should be able to determine for themselves their financial situation and what's best for their own family.
- We have a Statewide housing crisis, with over 65,000 new homes needed in Hawaii through 2025. 25,000 of those new homes are needed on Oahu alone. We should be focused on affordability of homes, especially since ne w homes are built much safer than ever before with better technology and fire-retardant materials.
- There are more cost-effective ways to keep your home safe from fires. Kitchen fires are the number one cause of home fires, and a homeowner can purchase suppression canisters to place over their stove that will activate when there are flames. Improved technology have brought us sensors that detect when there hasn't been any motion next to an active stovetop and automatically shuts off your stove.
- Sprinkler systems run the risk of water leaks, leading to mold and other damage to your home, which is probably your biggest asset.
- Education and prevention are key to keeping occupants and their home safe.

Thank you for the opportunity to express my support.

Sincerely,

Curt Kiriu
94-477 HAIWALE LOOP
MILILANI, HI 96789
curtk@hawaii.rr.com

From: Davelyn Leong <davelyn@dcrhawaii.com>
Sent: Thursday, February 23, 2017 5:26 PM
To: JUDtestimony
Subject: Support for H.B. 1384 H.D. 2 to Keep Sprinklers Optional

Dear Chair Nishimoto,

Dear Chair Nishimoto and members of the Committee,

I am in support of H.B. 1384 H.D. 2, which would keep residential fire sprinklers optional by extending the sunset date by a certain amount of time. I would strongly prefer the original version of this bill, which completely removes the sunset date. Or event the H.D. 1 version, which extends the sunset by 10 years.

I strongly support keeping residential fire sprinklers optional because:

- The cost to a homeowner on Oahu could be about \$35,000 for a system to be designed and installed, and much more on the neighbor islands. With median home prices at \$740,000, adding any more amount of money will easily prevent a family from getting into a home of their own. And, at these prices, a homeowner should be able to determine for themselves their financial situation and what's best for their own family.
- We have a Statewide housing crisis, with over 65,000 new homes needed in Hawaii through 2025. 25,000 of those new homes are needed on Oahu alone. We should be fo cused on affordability of homes, especially since new homes are built much safer than ever before with better technology and fire-retardant materials.
- There are more cost-effective ways to keep your home safe from fires. Kitchen fires are the number one cause of home fires, and a homeowner can purchase suppression canisters to place over their stove that will activate when there are flames. Improved technology have brought us sensors that detect when there hasn't been any motion next to an active stovetop and automatically shuts off your stove.
- Sprinkler systems run the risk of water leaks, leading to mold and other damage to your home, which is probably your biggest asset.
- Education and prevention are key to keeping occupants and their home safe.

Thank you for the opportunity to express my support.

Sincerely,

Davelyn Leong
731 Amana St Ph 1
Honolulu, HI 96814
davelyn@dcrhawaii.com

From: Dean Uchida <duchida@ssfm.com>
Sent: Thursday, February 23, 2017 6:34 PM
To: JUDtestimony
Subject: Support for H.B. 1384 H.D. 2 to Keep Sprinklers Optional

Dear Chair Nishimoto,

Dear Chair Nishimoto and members of the Committee,

I am in support of H.B. 1384 H.D. 2, which would keep residential fire sprinklers optional by extending the sunset date by a certain amount of time. I would strongly prefer the original version of this bill, which completely removes the sunset date. Or event the H.D. 1 version, which extends the sunset by 10 years.

I strongly support keeping residential fire sprinklers optional because:

- The cost to a homeowner on Oahu could be about \$35,000 for a system to be designed and installed, and much more on the neighbor islands. With median home prices at \$740,000, adding any more amount of money will easily prevent a family from getting into a home of their own. And, at these prices, a homeowner should be able to determine for themselves their financial situation and what's best for their own family.
- We have a Statewide housing crisis, with over 65,000 new homes needed in Hawaii through 2025. 25,000 of those new homes are needed on Oahu alone. We should be focused on affordability of homes, especially since new homes are built much safer than ever before with better technology and fire-retardant materials.
- There are more cost-effective ways to keep your home safe from fires. Kitchen fires are the number one cause of home fires, and a homeowner can purchase suppression canisters to place over their stove that will activate when there are flames. Improved technology have brought us sensors that detect when there hasn't been any motion next to an active stovetop and automatically shuts off your stove.
- Sprinkler systems run the risk of water leaks, leading to mold and other damage to your home, which is probably your biggest asset.
- Education and prevention are key to keeping occupants and their home safe.

Thank you for the opportunity to express my support.

Sincerely,

Dean Uchida
98-1762 KUPUKUPU ST
AIEA, HI 96701
duchida@ssfm.com

From: Edna Gomez <egomez@castlecooke.com>
Sent: Thursday, February 23, 2017 5:34 PM
To: JUDtestimony
Subject: Support for H.B. 1384 H.D. 2 to Keep Sprinklers Optional

Dear Chair Nishimoto,

Dear Chair Nishimoto and members of the Committee,

I am in support of H.B. 1384 H.D. 2, which would keep residential fire sprinklers optional by extending the sunset date by a certain amount of time. I would strongly prefer the original version of this bill, which completely removes the sunset date. Or event the H.D. 1 version, which extends the sunset by 10 years.

I strongly support keeping residential fire sprinklers optional because:

- The cost to a homeowner on Oahu could be about \$35,000 for a system to be designed and installed, and much more on the neighbor islands. With median home prices at \$740,000, adding any more amount of money will easily prevent a family from getting into a home of their own. And, at these prices, a homeowner should be able to determine for themselves their financial situation and what's best for their own family.
- We have a Statewide housing crisis, with over 65,000 new homes needed in Hawaii through 2025. 25,000 of those new homes are needed on Oahu alone. We should be focused on affordability of homes, especially since new homes are built much safer than ever before with better technology and fire-retardant materials.
- There are more cost-effective ways to keep your home safe from fires. Kitchen fires are the number one cause of home fires, and a homeowner can purchase suppression canisters to place over their stove that will activate when there are flames. Improved technology have brought us sensors that detect when there hasn't been any motion next to an active stovetop and automatically shuts off your stove.
- Sprinkler systems run the risk of water leaks, leading to mold and other damage to your home, which is probably your biggest asset.
- Education and prevention are key to keeping occupants and their home safe.

Thank you for the opportunity to express my support.

Sincerely,

Edna Gomez
95-1031 HALEPAHU ST
MILILANI, HI 96789
egomez@castlecooke.com

From: Gregory Thielen <greg@ccs-hawaii.com>
Sent: Thursday, February 23, 2017 5:32 PM
To: JUDtestimony
Subject: Support for H.B. 1384 H.D. 2 to Keep Sprinklers Optional

Dear Chair Nishimoto,

Dear Chair Nishimoto and members of the Committee,

I am in support of H.B. 1384 H.D. 2, which would keep residential fire sprinklers optional by extending the sunset date by a certain amount of time. I would strongly prefer the original version of this bill, which completely removes the sunset date. Or event the H.D. 1 version, which extends the sunset by 10 years.

I strongly support keeping residential fire sprinklers optional because:

- The cost to a homeowner on Oahu could be about \$35,000 for a system to be designed and installed, and much more on the neighbor islands. With median home prices at \$740,000, adding any more amount of money will easily prevent a family from getting into a home of their own. And, at these prices, a homeowner should be able to determine for themselves their financial situation and what's best for their own family.
- We have a Statewide housing crisis, with over 65,000 new homes needed in Hawaii through 2025. 25,000 of those new homes are needed on Oahu alone. We should be focused on affordability of homes, especially since new homes are built much safer than ever before with better technology and fire-retardant materials.
- There are more cost-effective ways to keep your home safe from fires. Kitchen fires are the number one cause of home fires, and a homeowner can purchase suppression canisters to place over their stove that will activate when there are flames. Improved technology have brought us sensors that detect when there hasn't been any motion next to an active stovetop and automatically shuts off your stove.
- Sprinkler systems run the risk of water leaks, leading to mold and other damage to your home, which is probably your biggest asset.
- Education and prevention are key to keeping occupants and their home safe.

Thank you for the opportunity to express my support.

Sincerely,

Gregory Thielen
63 Kalaka Pl
Kailua, HI 96734
greg@ccs-hawaii.com

From: Joan Sato <Joan@JSatoAssociates.com>
Sent: Thursday, February 23, 2017 5:23 PM
To: JUDtestimony
Subject: Support for H.B. 1384 H.D. 2 to Keep Sprinklers Optional

Dear Chair Nishimoto,

Dear Chair Nishimoto and members of the Committee,

I am in support of H.B. 1384 H.D. 2, which would keep residential fire sprinklers optional by extending the sunset date by a certain amount of time. I would strongly prefer the original version of this bill, which completely removes the sunset date. Or event the H.D. 1 version, which extends the sunset by 10 years.

I strongly support keeping residential fire sprinklers optional because:

- The cost to a homeowner on Oahu could be about \$35,000 for a system to be designed and installed, and much more on the neighbor islands. With median home prices at \$740,000, adding any more amount of money will easily prevent a family from getting into a home of their own. And, at these prices, a homeowner should be able to determine for themselves their financial situation and what's best for their own family.
- We have a Statewide housing crisis, with over 65,000 new homes needed in Hawaii through 2025. 25,000 of those new homes are needed on Oahu alone. We should be focused on affordability of homes, especially since new homes are built much safer than ever before with better technology and fire-retardant materials.
- There are more cost-effective ways to keep your home safe from fires. Kitchen fires are the number one cause of home fires, and a homeowner can purchase suppression canisters to place over their stove that will activate when there are flames. Improved technology have brought us sensors that detect when there hasn't been any motion next to an active stovetop and automatically shuts off your stove.
- Sprinkler systems run the risk of water leaks, leading to mold and other damage to your home, which is probably your biggest asset.
- Education and prevention are key to keeping occupants and their home safe.

Thank you for the opportunity to express my support.

Sincerely,

Joan Sato
2232 Kapiolani Blvd Apt 804
Honolulu, HI 96826
Joan@JSatoAssociates.com

From: Karen Berry <karen@tradepublishing.com>
Sent: Thursday, February 23, 2017 5:40 PM
To: JUDtestimony
Subject: Support for H.B. 1384 H.D. 2 to Keep Sprinklers Optional

Dear Chair Nishimoto,

Dear Chair Nishimoto and members of the Committee,

I am in support of H.B. 1384 H.D. 2, which would keep residential fire sprinklers optional by extending the sunset date by a certain amount of time. I would strongly prefer the original version of this bill, which completely removes the sunset date. Or event the H.D. 1 version, which extends the sunset by 10 years.

I strongly support keeping residential fire sprinklers optional because:

- The cost to a homeowner on Oahu could be about \$35,000 for a system to be designed and installed, and much more on the neighbor islands. With median home prices at \$740,000, adding any more amount of money will easily prevent a family from getting into a home of their own. And, at these prices, a homeowner should be able to determine for themselves their financial situation and what's best for their own family.
- We have a Statewide housing crisis, with over 65,000 new homes needed in Hawaii through 2025. 25,000 of those new homes are needed on Oahu alone. We should be focused on affordability of homes, especially since new homes are built much safer than ever before with better technology and fire-retardant materials.
- There are more cost-effective ways to keep your home safe fr om fires. Kitchen fires are the number one cause of home fires, and a homeowner can purchase suppression canisters to place over their stove that will activate when there are flames. Improved technology have brought us sensors that detect when there hasn't been any motion next to an active stovetop and automatically shuts off your stove.
- Sprinkler systems run the risk of water leaks, leading to mold and other damage to your home, which is probably your biggest asset.
- Education and prevention are key to keeping occupants and their home safe.

Thank you for the opportunity to express my support.

Mahalo for all you do for Hawaii!

Sincerely,

Karen Berry
60 N Beretania St Apt 3502
Honolulu, HI 96817
karen@tradepublishing.com

From: Laurie Ann Chan <lc@avalonhi.com>
Sent: Thursday, February 23, 2017 5:32 PM
To: JUDtestimony
Subject: Support for H.B. 1384 H.D. 2 to Keep Sprinklers Optional

Dear Chair Nishimoto,

Dear Chair Nishimoto and members of the Committee,

I am in support of H.B. 1384 H.D. 2, which would keep residential fire sprinklers optional by extending the sunset date by a certain amount of time. I would strongly prefer the original version of this bill, which completely removes the sunset date. Or event the H.D. 1 version, which extends the sunset by 10 years.

I strongly support keeping residential fire sprinklers optional because:

- The cost to a homeowner on Oahu could be about \$35,000 for a system to be designed and installed, and much more on the neighbor islands. With median home prices at \$740,000, adding any more amount of money will easily prevent a family from getting into a home of their own. And, at these prices, a homeowner should be able to determine for themselves their financial situation and what's best for their own family.
- We have a Statewide housing crisis, with over 65,000 new homes needed in Hawaii through 2025. 25,000 of those new homes are needed on Oahu alone. We should be focused on affordability of homes, especially since new homes are built much safer than ever before with better technology and fire-retardant materials.
- There are more cost-effective ways to keep your home safe from fires. Kitchen fires are the number one cause of home fires, and a homeowner can purchase suppression canisters to place over their stove that will activate when there are flames. Improved technology have brought us sensors that detect when there hasn't been any motion next to an active stovetop and automatically shuts off your stove.
- Sprinkler systems run the risk of water leaks, leading to mold and other damage to your home, which is probably your biggest asset.
- Education and prevention are key to keeping occupants and their home safe.

Thank you for the opportunity to express my support.

Sincerely,

Laurie Ann Chan
2003 Mahaoo Pl
Honolulu, HI 96819
lc@avalonhi.com

LATE

JUDtestimony

From: Margaret Wong <margaret@copelandgroupusa.com>
Sent: Friday, February 24, 2017 10:47 AM
To: JUDtestimony
Subject: Support for H.B. 1384 H.D. 2 to Keep Sprinklers Optional

Dear Chair Nishimoto,

Dear Chair Nishimoto and members of the Committee,

I am in support of H.B. 1384 H.D. 2, which would keep residential fire sprinklers optional by extending the sunset date by a certain amount of time. I would strongly prefer the original version of this bill, which completely removes the sunset date. Or event the H.D. 1 version, which extends the sunset by 10 years.

I strongly support keeping residential fire sprinklers optional because:

- The cost to a homeowner on Oahu could be about \$35,000 for a system to be designed and installed, and much more on the neighbor islands. With median home prices at \$740,000, adding any more amount of money will easily prevent a family from getting into a home of their own. And, at these prices, a homeowner should be able to determine for themselves their financial situation and what's best for their own family.
- We have a Statewide housing crisis, with over 65,000 new homes needed in Hawaii through 2025. 25,000 of those new homes are needed on Oahu alone. We should be focused on affordability of homes, especially since new homes are built much safer than ever before with better technology and fire-retardant materials.
- There are more cost-effective ways to keep your home safe from fires. Kitchen fires are the number one cause of home fires, and a homeowner can purchase suppression canisters to place over their stove that will activate when there are flames. Improved technology have brought us sensors that detect when there hasn't been any motion next to an active stovetop and automatically shuts off your stove.
- Sprinkler systems run the risk of water leaks, leading to mold and other damage to your home, which is probably your biggest asset.
- Education and prevention are key to keeping occupants and their home safe.

Thank you for the opportunity to express my support.

Sincerely,

Margaret Wong
1360 S Beretania St Ste 209
Honolulu, HI 96814
margaret@copelandgroupusa.com

LATE

JUDtestimony

From: Frank Alexich <faalexich@screensandthings.net>
Sent: Friday, February 24, 2017 10:15 AM
To: JUDtestimony
Subject: Support for H.B. 1384 H.D. 2 to Keep Sprinklers Optional

Dear Chair Nishimoto,

Dear Chair Nishimoto and members of the Committee,

I am in support of H.B. 1384 H.D. 2, which would keep residential fire sprinklers optional by extending the sunset date by a certain amount of time. I would strongly prefer the original version of this bill, which completely removes the sunset date. Or event the H.D. 1 version, which extends the sunset by 10 years.

I strongly support keeping residential fire sprinklers optional because:

- The cost to a homeowner on Oahu could be about \$35,000 for a system to be designed and installed, and much more on the neighbor islands. With median home prices at \$740,000, adding any more amount of money will easily prevent a family from getting into a home of their own. And, at these prices, a homeowner should be able to determine for themselves their financial situation and what's best for their own family.
- We have a Statewide housing crisis, with over 65,000 new homes needed in Hawaii through 2025. 25,000 of those new homes are needed on Oahu alone. We should be focused on affordability of homes, especially since new homes are built much safer than ever before with better technology and fire-retardant materials.
- There are more cost-effective ways to keep your home safe from fires. Kitchen fires are the number one cause of home fires, and a homeowner can purchase suppression canisters to place over their stove that will activate when there are flames. Improved technology have brought us sensors that detect when there hasn't been any motion next to an active stovetop and automatically shuts off your stove.
- Sprinkler systems run the risk of water leaks, leading to mold and other damage to your home, which is probably your biggest asset.
- Education and prevention are key to keeping occupants and their home safe.

Thank you for the opportunity to express my support.

Sincerely,

Frank Alexich
7497 Kekaa St
Honolulu, HI 96825
faalexich@screensandthings.net

LATE

JUDtestimony

From: Craig Watase <cwatase@hawaii.rr.com>
Sent: Friday, February 24, 2017 10:33 AM
To: JUDtestimony
Subject: Support for H.B. 1384 H.D. 2 to Keep Sprinklers Optional

Dear Chair Nishimoto,

Aloha Chair Nishimoto. I am Craig Watase, President of Mark Development - and affordable housing developer and property manager. Affordable or new home market housing, fire sprinklers in new home technology has very little benefit in relation to the cost.

Dear Chair Nishimoto and members of the Committee,

I am in support of H.B. 1384 H.D. 2, which would keep residential fire sprinklers optional by extending the sunset date by a certain amount of time. I would strongly prefer the original version of this bill, which completely removes the sunset date. Or event the H.D. 1 version, which extends the sunset by 10 years.

I strongly support keeping residential fire sprinklers optional because:

- The cost to a homeowner on Oahu could be about \$35,000 for a system to be designed and installed, and much more on the neighbor islands. With median home prices at \$740,000, adding any more amount of money will easily prevent a family from getting into a home of their own. And, at these prices, a homeowner should be able to determine for themselves their financial situation and what's best for their own family.
- We have a Statewide housing crisis, with over 65,000 new homes needed in Hawaii through 2025. 25,000 of those new homes are needed on Oahu alone. We should be focused on affordability of homes, especially since new homes are built much safer than ever before with better technology and fire-retardant materials.
- There are more cost-effective ways to keep your home safe from fires. Kitchen fires are the number one cause of home fires, and a homeowner can purchase suppression canisters to place over their stove that will activate when there are flames. Improved technology have brought us sensors that detect when there hasn't been any motion next to an active stovetop and automatically shuts off your stove.
- Sprinkler systems run the risk of water leaks, leading to mold and other damage to your home, which is probably your biggest asset.
- Education and prevention are key to keeping occupants and their home safe.

Thank you for the opportunity to express my support.

Sincerely,

Craig Watase
489 Anolani St
Honolulu, HI 96821
cwatase@hawaii.rr.com

LATE

JUDtestimony

From: Arthur Pelkaus <artp@gentryhawaii.com>
Sent: Friday, February 24, 2017 10:45 AM
To: JUDtestimony
Subject: Support for H.B. 1384 H.D. 2 to Keep Sprinklers Optional

Dear Chair Nishimoto,

Dear Chair Nishimoto and members of the Committee,

I am in support of H.B. 1384 H.D. 2, which would keep residential fire sprinklers optional by extending the sunset date by a certain amount of time. I would strongly prefer the original version of this bill, which completely removes the sunset date. Or event the H.D. 1 version, which extends the sunset by 10 years.

I strongly support keeping residential fire sprinklers optional because:

- The cost to a homeowner on Oahu could be about \$35,000 for a system to be designed and installed, and much more on the neighbor islands. With median home prices at \$740,000, adding any more amount of money will easily prevent a family from getting into a home of their own. And, at these prices, a homeowner should be able to determine for themselves their financial situation and what's best for their own family.
- We have a Statewide housing crisis, with over 65,000 new homes needed in Hawaii through 2025. 25,000 of those new homes are needed on Oahu alone. We should be focused on affordability of homes, especially since new homes are built much safer than ever before with better technology and fire-retardant materials.
- There are more cost-effective ways to keep your home safe from fires. Kitchen fires are the number one cause of home fires, and a homeowner can purchase suppression canisters to place over their stove that will activate when there are flames. Improved technology have brought us sensors that detect when there hasn't been any motion next to an active stovetop and automatically shuts off your stove.
- Sprinkler systems run the risk of water leaks, leading to mold and other damage to your home, which is probably your biggest asset.
- Education and prevention are key to keeping occupants and their home safe.

Thank you for the opportunity to express my support.

Sincerely,

Arthur Pelkaus
1296 Kapiolani Blvd
Honolulu, HI 96814
artp@gentryhawaii.com

LATE

JUDtestimony

From: Tiare Pinto <tiare@archipelagohawaii.com>
Sent: Friday, February 24, 2017 11:27 AM
To: JUDtestimony
Subject: Support for H.B. 1384 H.D. 2 to Keep Sprinklers Optional

Dear Chair Nishimoto,

Dear Chair Nishimoto and members of the Committee,

I am in support of H.B. 1384 H.D. 2, which would keep residential fire sprinklers optional by extending the sunset date by a certain amount of time. I would strongly prefer the original version of this bill, which completely removes the sunset date. Or event the H.D. 1 version, which extends the sunset by 10 years.

I strongly support keeping residential fire sprinklers optional because:

- The cost to a homeowner on Oahu could be about \$35,000 for a system to be designed and installed, and much more on the neighbor islands. With median home prices at \$740,000, adding any more amount of money will easily prevent a family from getting into a home of their own. And, at these prices, a homeowner should be able to determine for themselves their financial situation and what's best for their own family.
- We have a Statewide housing crisis, with over 65,000 new homes needed in Hawaii through 2025. 25,000 of those new homes are needed on Oahu alone. We should be focused on affordability of homes, especially since new homes are built much safer than ever before with better technology and fire-retardant materials.
- There are more cost-effective ways to keep your home safe from fires. Kitchen fires are the number one cause of home fires, and a homeowner can purchase suppression canisters to place over their stove that will activate when there are flames. Improved technology have brought us sensors that detect when there hasn't been any motion next to an active stovetop and automatically shuts off your stove.
- Sprinkler systems run the risk of water leaks, leading to mold and other damage to your home, which is probably your biggest asset.
- Education and prevention are key to keeping occupants and their home safe.

Thank you for the opportunity to express my support.

Sincerely,

Tiare Pinto
45-201 NOHONANI PL
KANEEOHE, HI 96744
tiare@archipelagohawaii.com

JUDtestimony

From: Steven Gangwes <skgangwes@drhorton.com>
Sent: Friday, February 24, 2017 11:23 AM
To: JUDtestimony
Subject: Support for H.B. 1384 H.D. 2 to Keep Sprinklers Optional

Dear Chair Nishimoto,

Aloha Chair Nishimoto, I know this is a busy time at the for you, but I do want to let you know, that we appreciate your consideration and reading this message. Additionally, to let you know that I strongly agree with the language the BIA states below. Having worked in Hawaii residential development for about 25 years, I continue to see the cost escalating and the dream of home ownership for local families more difficult to obtain. We at D.R. Horton are striving to provide home for local families at prices they can afford. The additional cost for single-family fire sprinkler systems, will eliminate buyer's ability to afford the homes.

Dear Chair Nishimoto and members of the Committee,

I am in support of H.B. 1384 H.D. 2, which would keep residential fire sprinklers optional by extending the sunset date by a certain amount of time. I would strongly prefer the original version of this bill, which completely removes the sunset date. Or event the H.D. 1 version, which extends the sunset by 10 years.

I strongly support keeping residential fire sprinklers optional because:

- The cost to a homeowner on Oahu could be about \$35,000 for a system to be designed and installed, and much more on the neighbor islands. With median home prices at \$740,000, adding any more amount of money will easily prevent a family from getting into a home of their own. And, at these prices, a homeowner should be able to determine for themselves their financial situation and what's best for their own family.
- We have a Statewide housing crisis, with over 65,000 new homes needed in Hawaii through 2025. 25,000 of those new homes are needed on Oahu alone. We should be focused on affordability of homes, especially since new homes are built much safer than ever before with better technology and fire-retardant materials.
- There are more cost-effective ways to keep your home safe from fires. Kitchen fires are the number one cause of home fires, and a homeowner can purchase suppression canisters to place over their stove that will activate when there are flames. Improved technology have brought us sensors that detect when there hasn't been any motion next to an active stovetop and automatically shuts off your stove.
- Sprinkler systems run the risk of water leaks, leading to mold and other damage to your home, which is probably your biggest asset.
- Education and prevention are key to keeping occupants and their home safe.

Thank you for the opportunity to express my support.

Sincerely,

Steven Gangwes
1519 Nuuanu Ave Unit 12
Honolulu, HI 96817
skgangwes@drhorton.com

LATE

JUDtestimony

From: Gary Sufrin <gary@insolidhawaii.com>
Sent: Friday, February 24, 2017 11:51 AM
To: JUDtestimony
Subject: Support for H.B. 1384 H.D. 2 to Keep Sprinklers Optional

Dear Chair Nishimoto,

Dear Chair Nishimoto and members of the Committee,

I am in support of H.B. 1384 H.D. 2, which would keep residential fire sprinklers optional by extending the sunset date by a certain amount of time. I would strongly prefer the original version of this bill, which completely removes the sunset date. Or event the H.D. 1 version, which extends the sunset by 10 years.

I strongly support keeping residential fire sprinklers optional because:

- The cost to a homeowner on Oahu could be about \$35,000 for a system to be designed and installed, and much more on the neighbor islands. With median home prices at \$740,000, adding any more amount of money will easily prevent a family from getting into a home of their own. And, at these prices, a homeowner should be able to determine for themselves their financial situation and what's best for their own family.
- We have a Statewide housing crisis, with over 65,000 new homes needed in Hawaii through 2025. 25,000 of those new homes are needed on Oahu alone. We should be fo cused on affordability of homes, especially since new homes are built much safer than ever before with better technology and fire-retardant materials.
- There are more cost-effective ways to keep your home safe from fires. Kitchen fires are the number one cause of home fires, and a homeowner can purchase suppression canisters to place over their stove that will activate when there are flames. Improved technology have brought us sensors that detect when there hasn't been any motion next to an active stovetop and automatically shuts off your stove.
- Sprinkler systems run the risk of water leaks, leading to mold and other damage to your home, which is probably your biggest asset.
- Education and prevention are key to keeping occupants and their home safe.

Thank you for the opportunity to express my support.

Sincerely,

Gary Sufrin
667 Kaumakani St
Honolulu, HI 96825
gary@insolidhawaii.com

LATE

JUDtestimony

From: Ricky Li <rickyli99@gmail.com>
Sent: Friday, February 24, 2017 12:44 PM
To: JUDtestimony
Subject: Support for H.B. 1384 H.D. 2 to Keep Sprinklers Optional

Dear Chair Nishimoto,

Dear Chair Nishimoto and members of the Committee,

I am in support of H.B. 1384 H.D. 2, which would keep residential fire sprinklers optional by extending the sunset date by a certain amount of time. I would strongly prefer the original version of this bill, which completely removes the sunset date. Or event the H.D. 1 version, which extends the sunset by 10 years.

I strongly support keeping residential fire sprinklers optional because:

- The cost to a homeowner on Oahu could be about \$35,000 for a system to be designed and installed, and much more on the neighbor islands. With median home prices at \$740,000, adding any more amount of money will easily prevent a family from getting into a home of their own. And, at these prices, a homeowner should be able to determine for themselves their financial situation and what's best for their own family.
- We have a Statewide housing crisis, with over 65,000 new homes needed in Hawaii through 2025. 25,000 of those new homes are needed on Oahu alone. We should be fo cused on affordability of homes, especially since new homes are built much safer than ever before with better technology and fire-retardant materials.
- There are more cost-effective ways to keep your home safe from fires. Kitchen fires are the number one cause of home fires, and a homeowner can purchase suppression canisters to place over their stove that will activate when there are flames. Improved technology have brought us sensors that detect when there hasn't been any motion next to an active stovetop and automatically shuts off your stove.
- Sprinkler systems run the risk of water leaks, leading to mold and other damage to your home, which is probably your biggest asset.
- Education and prevention are key to keeping occupants and their home safe.

Thank you for the opportunity to express my support.

Sincerely,

Ricky Li
1425 Liliha St Apt 5H
Honolulu, HI 96817
rickyli99@gmail.com

LATE

JUDtestimony

From: LINDA KONDO <lindak3@servco.com>
Sent: Friday, February 24, 2017 1:58 PM
To: JUDtestimony
Subject: Support for H.B. 1384 H.D. 2 to Keep Sprinklers Optional

Dear Chair Nishimoto,

Dear Chair Nishimoto and members of the Committee,

I am in support of H.B. 1384 H.D. 2, which would keep residential fire sprinklers optional by extending the sunset date by a certain amount of time. I would strongly prefer the original version of this bill, which completely removes the sunset date. Or event the H.D. 1 version, which extends the sunset by 10 years.

I strongly support keeping residential fire sprinklers optional because:

- The cost to a homeowner on Oahu could be about \$35,000 for a system to be designed and installed, and much more on the neighbor islands. With median home prices at \$740,000, adding any more amount of money will easily prevent a family from getting into a home of their own. And, at these prices, a homeowner should be able to determine for themselves their financial situation and what's best for their own family.
- We have a Statewide housing crisis, with over 65,000 new homes needed in Hawaii through 2025. 25,000 of those new homes are needed on Oahu alone. We should be focused on affordability of homes, especially since new homes are built much safer than ever before with better technology and fire-retardant materials.
- There are more cost-effective ways to keep your home safe from fires. Kitchen fires are the number one cause of home fires, and a homeowner can purchase suppression canisters to place over their stove that will activate when there are flames. Improved technology have brought us sensors that detect when there hasn't been any motion next to an active stovetop and automatically shuts off your stove.
- Sprinkler systems run the risk of water leaks, leading to mold and other damage to your home, which is probably your biggest asset.
- Education and prevention are key to keeping occupants and their home safe.

Thank you for the opportunity to express my support.

Sincerely,

LINDA KONDO
94-1049 MOLALE ST
WAIPAHU, HI 96797
lindak3@servco.com

LATE

JUDtestimony

From: Mike Brant <mikeb@gentryhawaii.com>
Sent: Friday, February 24, 2017 3:50 PM
To: JUDtestimony
Subject: Support for H.B. 1384 H.D. 2 to Keep Sprinklers Optional

Dear Chair Nishimoto,

Dear Chair Nishimoto and members of the Committee,

I am in support of H.B. 1384 H.D. 2, which would keep residential fire sprinklers optional by extending the sunset date by a certain amount of time. I would strongly prefer the original version of this bill, which completely removes the sunset date. Or event the H.D. 1 version, which extends the sunset by 10 years.

I strongly support keeping residential fire sprinklers optional because:

- The cost to a homeowner on Oahu could be about \$35,000 for a system to be designed and installed, and much more on the neighbor islands. With median home prices at \$740,000, adding any more amount of money will easily prevent a family from getting into a home of their own. And, at these prices, a homeowner should be able to determine for themselves their financial situation and what's best for their own family.
- We have a Statewide housing crisis, with over 65,000 new homes needed in Hawaii through 2025. 25,000 of those new homes are needed on Oahu alone. We should be fo cused on affordability of homes, especially since new homes are built much safer than ever before with better technology and fire-retardant materials.
- There are more cost-effective ways to keep your home safe from fires. Kitchen fires are the number one cause of home fires, and a homeowner can purchase suppression canisters to place over their stove that will activate when there are flames. Improved technology have brought us sensors that detect when there hasn't been any motion next to an active stovetop and automatically shuts off your stove.
- Sprinkler systems run the risk of water leaks, leading to mold and other damage to your home, which is probably your biggest asset.
- Education and prevention are key to keeping occupants and their home safe.

Thank you for the opportunity to express my support.

Sincerely,

Mike Brant
2101 Nuuanu Ave Apt 1304
Honolulu, HI 96817
mikeb@gentryhawaii.com